

T-DAVIT®

Custom designed davits with WLL to 750kg

		
<p>SERIES A Standard T-DAVIT Beam with dual shackles</p>	<p>SERIES B Standard Winched T-DAVIT Beam & shackles</p>	<p>SERIES D Sliding Beam T-DAVIT with dual shackles</p>
		
<p>SERIES E Winched Sliding Beam T-DAVIT & shackles - Upper Winch</p>	<p>SERIES F Winched Sliding Beam T-DAVIT & shackles - Lower Winch</p>	<p>SERIES G T-DAVIT Beam for Geared Trolley with End Stops</p>

NOW
fully EN795
Type B
compliant

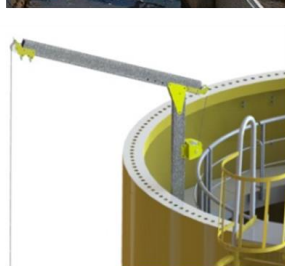

Product Information

www.reidlifting.com

REID
LIFTING
LIGHTWEIGHT | PORTABLE | SAFE

TD/EN/V6/2013/06/02



500Kg
WLL



1
person



customised
& bagged



1
person



REID's T-DAVIT custom davit cranes provide an extensive range of systems that enhances its PORTA-DAVIT family of lightweight lifting solutions. Most systems can be located, assembled and operated by just one person, in the most challenging situations.

A "bagged" solution makes it simple for engineers to carry the DAVIT to each job and store centrally or in service vehicles. This means that just **ONE** DAVIT can replace **MANY** fixed traditional systems, with the resultant savings in capital and maintenance as well as many operational benefits including health & safety considerations.

The T-DAVIT range of customised options includes Chain-block and Winched lifting across a range of configurations designed to address the difficult and often confined space lifting requirements; frequently providing a unique solution to otherwise impossible or highly manpower or equipment intensive and expensive lifting challenges.

Being individually developed, innovative custom solutions, the T-DAVIT capability provides a wide and ever growing range of configurations, options and solutions – so, please discuss your specific lifting challenges and requirements with REID Lifting.

T-DAVIT **A & B** series systems have undergone **EN795 Type B witnessed testing** and a range of options been proven to be compliant for such Fall Protection and Personnel Positioning applications, as well as goods lifting.

General Purpose Offshore Cranes" standard: **BS EN 13852-1:2004** options **also now** available for **Series A & B**:

N.B. All lifts should follow the relevant Risk Assessment and Method Statement and be undertaken by personnel trained in the safe use of the equipment used.

T-DAVITs are available in a wide range of configurations to meet your specific requirements:





SERIES A Standard T-DAVIT Beam with shackles	SERIES B Standard Winched T-DAVIT Beam & shackles	SERIES D Sliding Beam T-DAVIT with shackles	SERIES E Winched Sliding Beam T-DAVIT & shackles - Upper Winch	SERIES F Winched Sliding Beam T-DAVIT & shackles - Lower Winch	SERIES G T-DAVIT Beam for Geared Trolley with End Stops

T-DAVIT Family Capabilities:

Being custom units each T-DAVIT is designed for specific applications with options such as Winches, Trolley radius adjustment, jib radius adjustment, angled beam, etc.

- **WLL ratings to 500Kg for 65mm systems and 750kg with NEW "H" column**
- **Series A & B supplied with dual positions** - horizontal (Pos A) and angled (23°) Pos(B)
- **Standard Radius from 500mm to 2000mm (Custom to 3000mm) with reduced range of WLLs** - see TD capability table
- **EN795 Type B compliant options available (Series A & B)** - witnessed tested
- **General Purpose Offshore Cranes" standard: BS EN 13852-1:2004** compliant options available (Series A & B) - witnessed tested
- **Custom Series D, E & F provide dynamic radius adjustment under load and Series G a geared trolley system** for easy load positioning
- Height and Radius customisable - Height of lift can be increased with socket extensions
- Radius adjustments range options available in 100mm increments
- Patented, ultra-low friction bearing system for easy 360° rotation.
- Weight - within Manual Handling guidelines
- Anodised finish -for environmental protection & options suitable for clean environments
- Simple, rapid assembly - 2 piece design, no tools required
- Portable - Flat-pack in heavy duty bags - high utility & manual handling compliant
- Winch or shackle (x2) use as well as master link trolley options
- Many support options - Integral wheel carrier, Rotation control/locking aids, etc.

(65mm diameter Sockets, as per the PORTA-DAVIT, excluding the PORTA-BASE. "H" column systems require 95mm diameter sockets)



Flush Mount

Top Mount

Side Mount

Bridge Mount

Bespoke

Socket Extensions



500kg WLL



1 person



customised & bagged



1 person

T-DAVIT capabilities and dimensions:

"65" Series A & B:

FEATURES

- Rating of this 65mm socket T-DAVIT:
 - Goods rated up to WLL 500kg *see N.B.* or
 - *1 person fall arrest (EN795:2012) and personnel winching options available
 - Operational radius up to 3000mm**
 - 2 lifting positions as standard (A&B)
 - Unique bearing design for ease of rotation
 - Assembly & operation by one person; no tools required
 - Socket extensions available for additional height and optimum column length
 - Twin shackles for index lifting and/or attachments for winching
 - Wide range of sockets available
 - Supplied in heavy duty bag(s) for ease of transportation & protective storage
 - Anodised finish for clean handling
 - Fits into a typical service van
 - * Available as upgrade
 - ** Subject to WLL reduction (1900mm max for EN795)
- Patent Pending

N.B. Greater capability available with the "H" Series family – to WLL 750kg

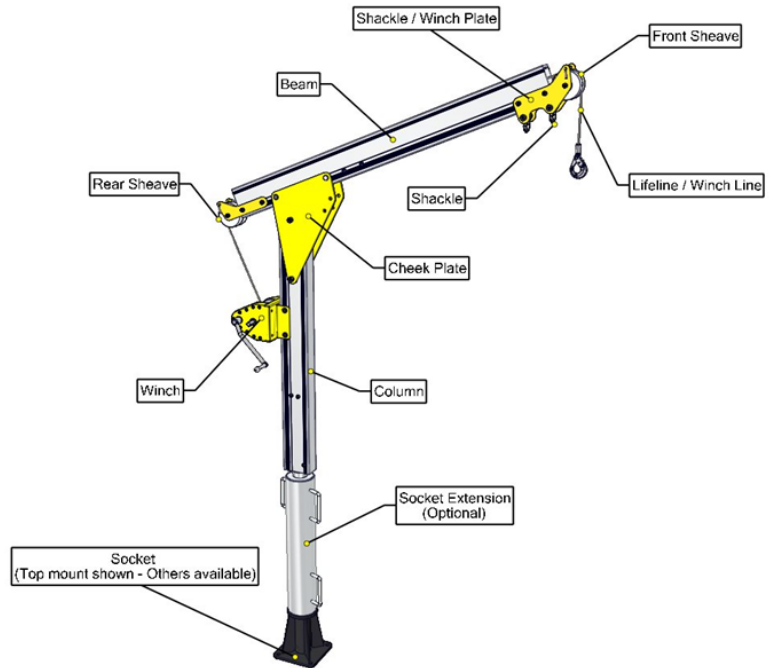

N.B.) Series B shown. For series A – no winch or sheaves; shackle plates only on front.

Options & Upgrades

- Integrated wheel carrier for reduced manual handling

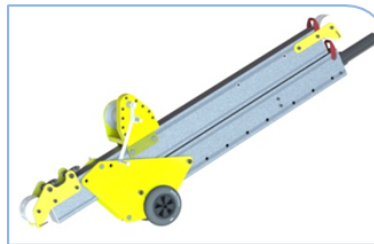

- Fall arrest, EN795:2012, and Personnel Winching options

- Beam radius adjustment

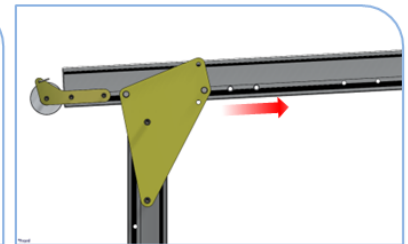

- For offshore use, EN13852-1:2004 options are available

Customisation and alternatives available.....



Series D
Sliding Beam



Series E
Winched Sliding Beam



Series F
Lower Winched Sliding Beam



Series G
Geared Trolley



"H" Column
Increased Load Capability

Tel: +44 (0)1291 620796

www.reidlifting.com



500kg
WLL



1
person



customised
& bagged



1
person

DIMENSIONS – “65” Series A – shackles only:

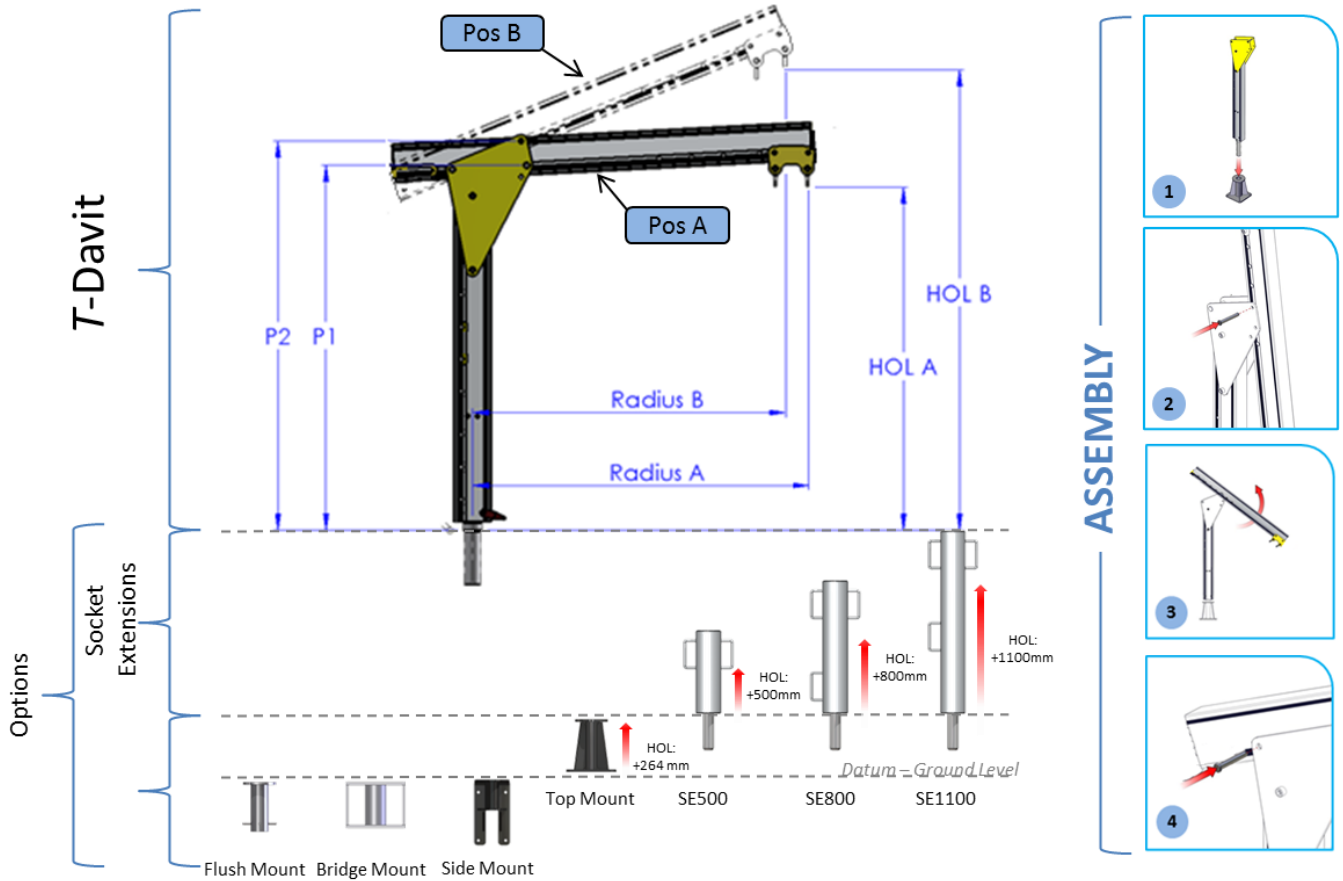

Beam Option	1		2		3		4		Maximum (Custom)		P1	P2
	A	B	A	B	A	B	A	B	A	B		
Position →												
Radius (mm) →	850	805	1050	990	1450	1358	1850	1730	(Up to) 2850	(Up to) 2655		
WLL Option 1 →	400kg		325kg		250kg		200kg		125kg			
WLL Option 2 →	500kg		400kg		300kg		250kg		150kg			
WLL Option 3 →			500kg		400kg		300kg		200kg			
Column Options ↓	↓ Height of Lift (HOL) to OUTER SHACKLE (mm) ↓											
1	919	1190	919	1266	919	1419	919	1571	919	1955	982	1081
2	1099	1370	1099	1446	1099	1599	1099	1751	1099	2097	1162	1261
3	1409	1680	1409	1756	1409	1909	1409	2061	1409	2445	1472	1571
4	1724	1995	1724	2071	1724	2224	1724	2376	1724	2760	1787	1886
5	2034	2305	2034	2381	2034	2534	2034	2686	2034	3070	2097	2196

V3/14/02

Tel: +44 (0)1291 620796

www.reidlifting.com



500kg
WLL



1
person



customised
& bagged



1
person

DIMENSIONS – “65” Series B – winched and shackled:

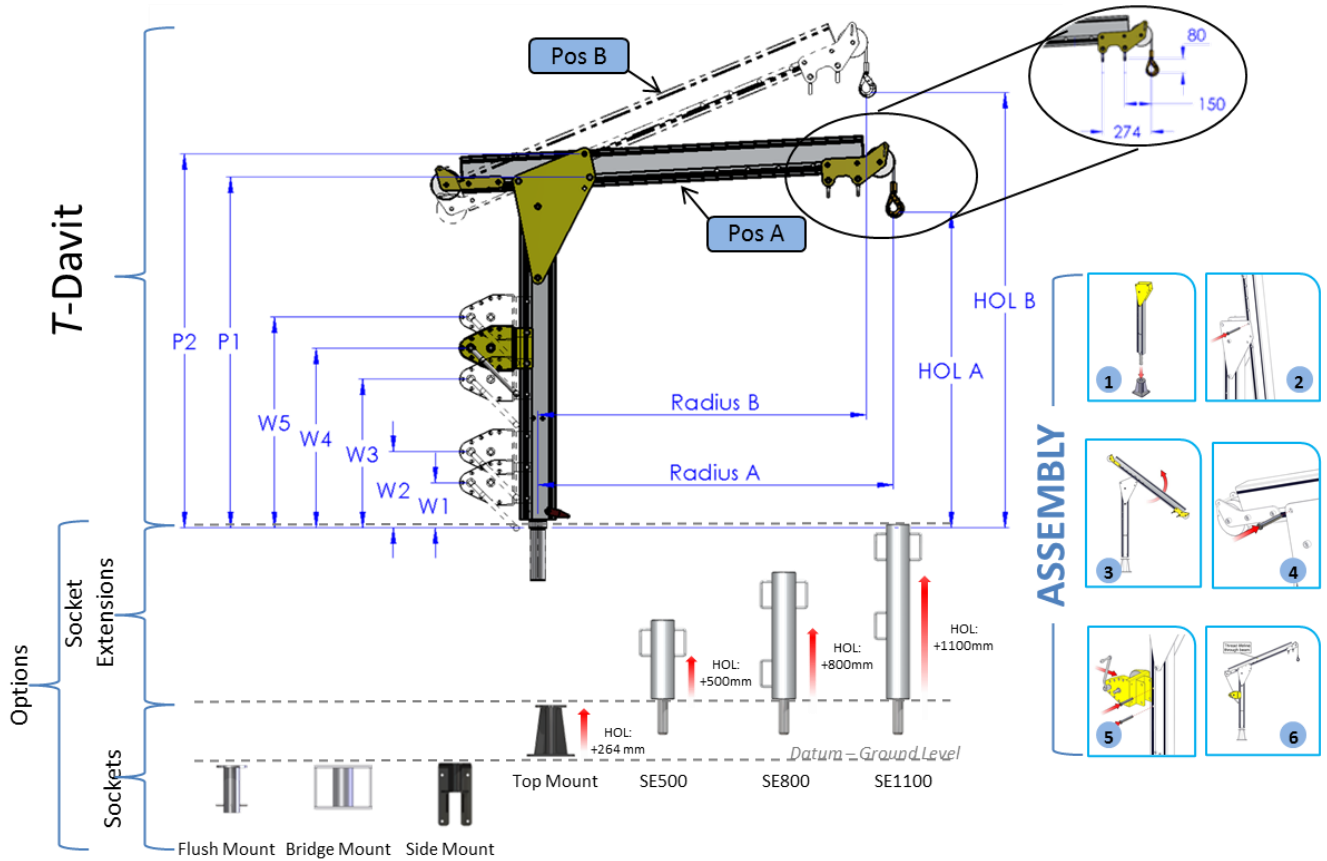

Beam Option →	1		2		3		4		Maximum (Custom)		Winch Position	P1	P2	
	A	B	A	B	A	B	A	B	A	B				
Position →														
Radius (mm) →	1000	925	1200	1110	1600	1478	2000	1850	(Up to) 3000	(Up to) 2775				
WLL Option 1 →	400kg		325kg		250kg		200kg		125kg					
WLL Option 2 →	500kg		400kg		300kg		250kg		150kg					
WLL Option 3 →			500kg		400kg		300kg		200kg					
Column Options ↓	↓ Height of Lift (HOL) to LIFTING HOOK (mm) ↓													
1	839	1151	839	1227	839	1380	839	1532	839	1916	W1 201 W2 331	982	1081	
2	1019	1331	1019	1407	1019	1560	1019	1712	1019	2097	W1 331 W2 331 W3 625	1162	1261	
3	1329	1641	1329	1717	1329	1870	1329	2022	1329	2406	W1 201 W2 331 W3 625 W4 755 W5 855	1472	1571	
4	1644	1956	1644	2032	1644	2185	1644	2337	1644	2721	W3 755 W4 885 W5 1015	1787	1886	
5	1954	2266	1954	2342	1954	2495	1954	2647	1954	3031	W3 755 W4 885 W5 1100	2097	2196	

V3/14/02



500Kg
WLL



1
person



customised
& bagged



1
person

65mm diameter Sockets – 95mm sockets are required for “H” column options:



Flush Mount

Top Mount

Side Mount

Bridge Mount

Bespoke

Socket Extensions

SOCKET RANGE TO SUIT DAVIT

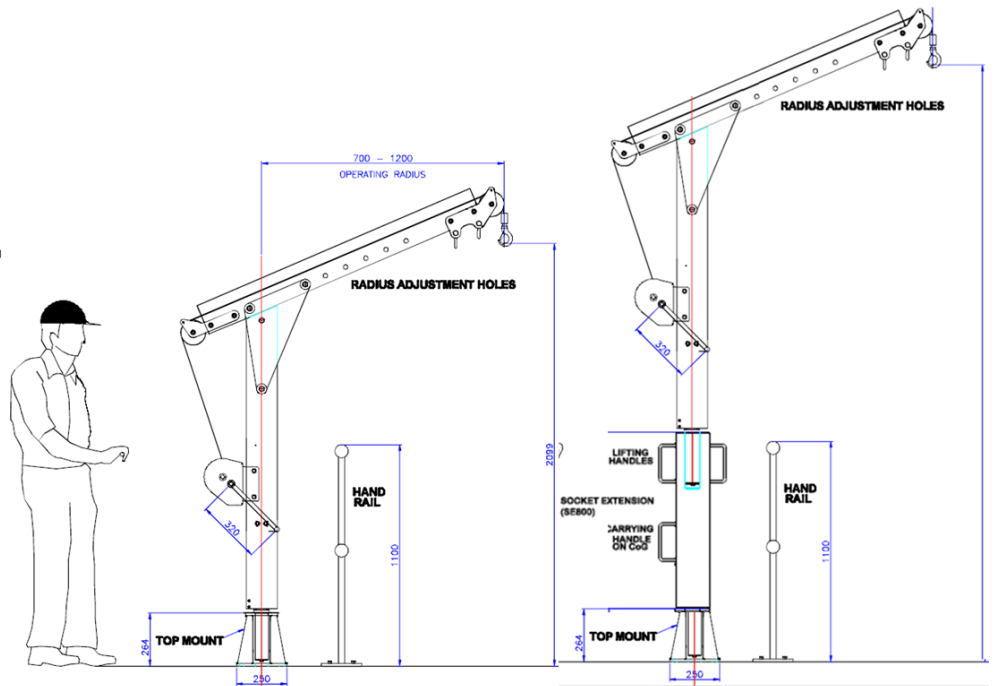
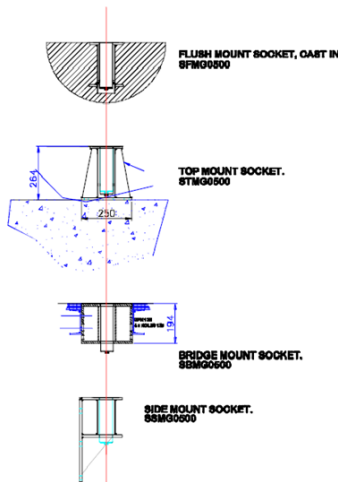



Custom designed davits with WLL to 500 kg



500kg
WLL



1
person



customised
& bagged



1
person

A & B Series to WLL 750kg – With “H” column & 95mm sockets:
Winch versions available to WLL 500kg

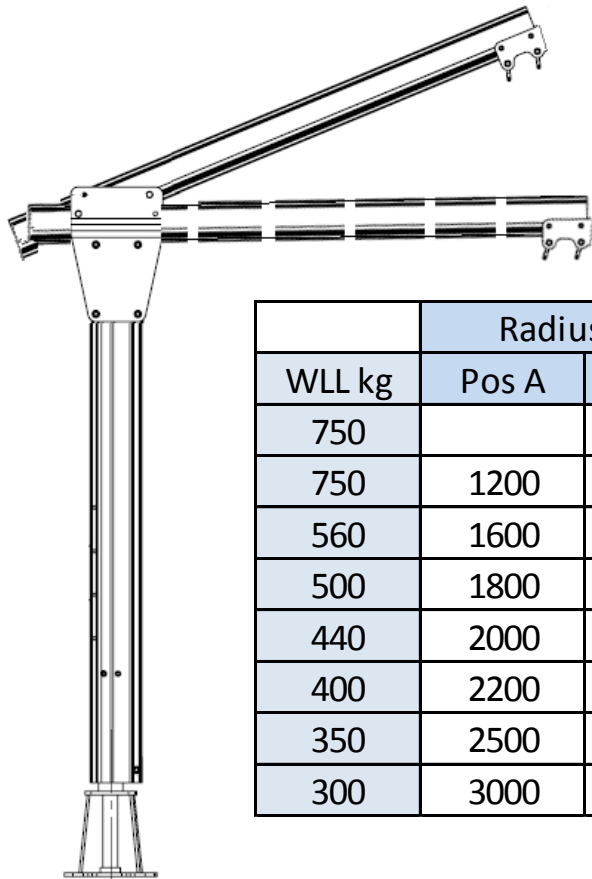

WLL kg	Radius mm	
	Pos A	Pos B
750		1200
750	1200	1110
560	1600	1478
500	1800	1665
440	2000	1850
400	2200	2035
350	2500	2312
300	3000	2775

“H” column for 95mm sockets:



95mm diameter sockets



Flush Mount

Top Mount

Bridge Mount

Side Mount

Please don't hesitate to contact REID Lifting to discuss your particular requirements.

Tel: +44 (0)1291 620796

www.reidlifting.com





500Kg
WLL



1
person



customised
& bagged



1
person

General Lifting Gear options – Chain blocks, hoists and winches

A wide range of lifting devices are available for use with the T-DAVIT:

Manual Chain blocks & winches as well as Electrical & Air hoists alternatives:



Please discuss your overall requirements with REID Lifting.

Chain Block: WLL 500kg RACBY000001

Manual Chain block range rated WLL 500kg, complete with 3.0m of load chain and 2.5m hand chain. The Chain block has unique design for operation of block at any angle to the load, allowing safe operation from side of load rather than the traditional system requiring chain to be pulled from directly underneath the chain block.

A load chain container, additional load chain and additional hand chain can be supplied if required.

Now available with Overload Protection as an option RACBY000001



Personnel Lifting and Fall Arrest & Retrieval options are available for compliant Series A & B variants:

REID provides a range of Personnel Lifting and Fall Arrest and Retrieval solutions, using the A&B Series EN795 compliant variants, based around best in class Personnel Lifting Winches and Fall Arrest & Retrieval units; customised to meet clients' operating requirements.



Please discuss all such applications with REID to select the optimum solution.



Custom designed davits with WLL to 500 kg



500Kg WLL



1 person



customised & bagged



1 person

REID Lifting - the best night's sleep in the lifting industry

Systems are type tested at UKAS accredited laboratories	Lifting Equipment Engineers Association (LEEA) full mebership	OHSAS18001 Occupational Health & Safety Management certification
Every individual system is fully inspected or tested prior to shipment	ISO9001 Quality Management System certification	Certification of products by relevant recognised bodies from sockets to systems
Full product design & development Technical Files are available for inspection	ISO14001 certification environment management systems and standards	Safe assembly, operation & maintenance manuals and training provided for all systems



Full LEEA Membership



ISO 9001



ISO 14001



OHSAS 18001



Queens Award Winners



CALL US

+44 (0)1291 620796

EMAIL US

sales@reidlifting.com

WEB

www.reidlifting.com



PORTA-GANTRY



PORTA-GANTRY RAPIDE



PORTA-DAVIT



T-DAVIT



PORTA-LIFTER



LIGHTWEIGHT | PORTABLE | SAFE

All information herein is copyright protected by Reid Lifting Ltd. All company and product names are Trade Mark and Trade Name protected and all REID Product IPR is protected under Patents, Patents Pending and/or Design Rights.

Tel: +44 (0)1291 620796

www.reidlifting.com

