



...PORTA-DAVIT™ 500



ASSEMBLY VIDEO

Assembly & Operation

www.reidlifting.com



PORTA-DAVIT™ 500

No. 1 in lightweight, portable, safe lifting solutions

CONTENTS

INTRODUCTION

CORRECT OPERATION

- Intended Use
- Inspection Prior to Initial Operation
- Inspection Before Starting Work
- Maximum Capacity

NOTES FOR CORRECT USAGE

- Warning
- Attaching the Load
- Temperature Range
- Regulations

INSPECTION/MAINTENANCE

- Regular Inspections
- Maintenance/Repair
- Storage and Transportation

SOCKETS

- Socket Installation
- Verifying the Installation

MARKING

ATEX

- ATEX - Classification
- ATEX - Identification
- ATEX - Spark Formation
- ATEX - Static Electricity
- ATEX - Inspection, Maintenance & Repair

LANGUAGE

ASSEMBLY INSTRUCTIONS

- PORTA-DAVIT 500 - Strop Version (standard)
- PORTA-DAVIT 500 - Winched

OTHER VARIATIONS

- PORTA-DAVIT 350EX
- PORTA-DAVIT plus Socket Extension

QUALITY & SAFETY

- Accreditations

TESTING

PRODUCT IPR

INSPECTION RECORD

INTRODUCTION

All users must read these operating instructions carefully prior to the initial operation. These instructions are intended to acquaint the user with the *PORTA-DAVIT 500* and enable him/her to use it to the full extent of its intended capabilities.

The operating instructions contain important information on how to handle the davit in a safe, correct and economic manner. Acting in accordance with these instructions helps to avoid dangers, reduce repair costs and down time and to increase reliability and lifetime of the davit.

Anyone involved in doing any of the following work with the *PORTA-DAVIT 500* must read the operation instructions and act accordingly:

- Operation, including preparation, trouble shooting during operation and cleaning
- Maintenance, inspection, repair
- Transport

Apart from the operating guide, health & safety and accident prevention act valid for the respective country and area where the equipment is used, the commonly accepted regulations for safe and professional work must be adhered to.

It is incumbent on the user or instigator of work with the equipment that all users have suitable medical and physical capabilities. Likewise the competent person should ensure there is a rescue plan in place in the event of an emergency that could occur during the work.

N.B. This document should form an element of the overriding Risk Assessment and Method Statement required for each lift.

No. 1 in lightweight, portable, safe lifting solutions

CORRECT OPERATION

Intended Use

The PORTA-DAVIT 500 is intended to be used for the lifting of goods or the lifting of persons, or for providing a safety anchor for the prevention of falls.

N.B. We recommend that the device is dedicated to either goods or personnel use and where reasonably practicable to avoid using the structure for both.

Inspection Prior to Initial Operation

Each davit must be inspected prior to initial operation by a competent person. The inspection is visual and functional and shall establish that the structure is safe and has not been damaged by incorrect assembly, transport or storage. The inspection should particularly concentrate on:

- Dents or indentations on the kingpin, jib, backstay (if present) and column surfaces
- Straightness of jib and column sections
- Elongation of the jib holes, column holes or backstay connection holes
- Damage to the shackles, strop (signs of fraying – the strop is manufactured from polyester; if signs of damage, UV degradation or wear REID recommend it is replaced)

The above list is not exhaustive. Inspections are instigated by the user.

Inspection Before Starting Work

The inspection procedure requires that a valid inspection/test certificate has been submitted to and checked by the user.

Before starting work, inspect the davit tubes and all load bearing components for visual defects. Furthermore, test the free rotation of the kingpin and ensure that it is fully engaged in the socket. To check whether the kingpin is fully engaged, ensure that the bottom of the column is flush with the top of the socket. This inspection requirement covers only the davit. Ensure that the overall working load limit (WLL) is adhered to – following the necessary Risk Assessment and Method Statement.

Maximum Capacity

The PORTA-DAVIT 500 is designed to lift and lower loads up to its rated capacity. The capacity indicated on the product is the maximum working load limit (WLL) or safe working load (SWL) which must not be exceeded (definition is country dependent).

When being used as a personnel lifting anchor the user must use a body harness and retractable device or shock absorber that complies with EN355 that limits the maximum arrest force (M.A.F) to 6kN. Personnel winches used with the PORTA-DAVIT 500 should comply to EN1496:2017 or equivalent.

Only **ONE** person/load may be attached to the davit structure in accordance with the WLL.

If the davit is to be used for personnel winching the WLLs must be observed. It is possible for the davit to have a WLL higher than is allowable when used with a fall arrest device. This is for situations where the structure is to be used as an anchor for lifting persons that have **no possibility of falling through a free distance** or when drafting out a rescue plan and should only be carried out following a comprehensive risk assessment.

N.B. If winching, a secondary line/fall arrest unit may also be required.

While the PORTA-DAVIT 500 will have the capabilities stated on the product it is only one part of a fall arrest system which is only as strong as the lowest rated component. Each lift must be properly planned and all weights clearly known along with the WLL and constraints of all fall arrest system devices.

In the event of simultaneous goods and personnel combined lifting or when being used as a fall arrest system in sub-zero AND wet conditions contact the supplier as capacities may be reduced.

Only a chain hoist up to a capacity of 1000kg may be used with the davit. The structure has been designed such that the weight of a chain block can be neglected, however if using a device with a significant weight it should be included into the WLL.

In the event of using a lifting device other than a manual chain hoist particular attention must be paid to the dynamic effects induced into the structure and it may be required to reduce the WLL of the structure. If in doubt contact your REID Lifting representative.

N.B. Stated radii achieved at \approx 75% WLL.

NOTES FOR CORRECT USAGE

- We recommend the use of load-sensing or overload protection devices on all lifts
- The WLL (or SWL) rating must **NOT** be exceeded – Risk Assessment and Method Statement must consider additional loading in 'wet lift' or 'break-out force' situations
- Ensure suitable winches and winch connection plates are used for all applications
- Due care and attention should be practiced when transporting and storing the product to avoid damage
- Do not throw the product or its components down or stack items on top of it. Always place properly on the ground to avoid damaging the equipment
- Assemble only as instructed (ensure all bolts are present and fitted correctly as per instructions)
- We recommend that gloves are worn when using this equipment
- Do not assemble davit in non-approved sockets
- Do not use the davit if the kingpin shaft is not seated correctly in the socket
- Do not use the davit if it does not rotate freely in the bearing or the bottom flange is fouled in any way, preventing free rotation of the davit
- Do not knot or shorten the tension strap to reduce operating radius
- Attach hoist only to one of the two lifting points
- Lift only when load chain/rope forms a vertical line between load and lifting shackle used
- Set up the product in its mounting socket ensuring that it is a safe location and there is no risk of falling into the hazard and davit is set at the correct operating radius for the job
- Persons are forbidden to walk or stand in dangerous areas
- Attach the load only to the lifting points on the head or the lifeline/winch-line
- Do not allow the load to swing
- When lifting keep the load as low to the ground as possible
- If the davit is to be used in special atmospheres contact your supplier
- When using the davit as a fall arrest anchor the required clearance of the fall arrest device should be considered - refer to the device's Operations and Maintenance manual
- **NEVER** walk away from structure whilst connected to the equipment i.e. connected by a fall arrest block or winch
- Before the davit is used, consideration must be given to the potential effects of the ropes running over sharp edges, chemical reagents, electrical conductivity, cutting, abrasion, climatic exposure and the effect of offset forces as a result of pendulum falls

No. 1 in lightweight, portable, safe lifting solutions

Warning

- The equipment shall not be used outside its limitations, or for any purpose other than that for which it is intended
- Do not allow personnel to pass under a suspended load
- **NEVER** leave a suspended load unattended.
- The PORTA-DAVIT 500 can only be used for lifting or arresting the fall of **ONE** person
- It is **NOT** recommended to mix the use of the davit with personnel and goods lifting concurrently
- Be aware of hazards when setting up/setting down
- It is essential for safety that the davit is withdrawn from use immediately should:
 1. Any doubt arise about its condition for safe use
Or
 2. It has been used to arrest a fall, and not be used again until confirmed in writing by a competent person that it is acceptable to do so

Disclaimer



All REID Lifting sockets & extensions have been designed, developed and tested for safe use with REID equipment and form a key part of the integrity of the total system.

- All sockets have a working load limit (WLL) based on the maximum radius setting of the davit, and the socket installation and verification tests performed
- All sockets are supplied in galvanised mild steel, stainless steel (316L grade, passivated) or aluminium
- Sockets can be powder coated upon request e.g. Yellow for trip hazard warning

Should non-standard third party sockets be used, REID Lifting's Declaration of Conformity & Incorporation on the products is negated. i.e. The system becomes the responsibility of the client.

Attaching the Load

The operator must ensure that the load is attached in a manner that does not expose him or other personnel to danger by the hoist, chain(s) or the load.

Temperature Range

The davit can be operated in ambient dry temperatures between -20°C and +50°C (-4°F to 122°F). Consult your supplier in case of extreme working conditions.

If used in sub-zero and wet conditions, the performance may be affected.

Regulations

The PORTA-DAVIT 500 complies with the following regulations:

PPE Regulation (EU) 2016/425, Machinery Directive 2006/42/EC, ATEX Directive 2014/34/EU, The Provision and Use of Work Equipment Regulations 1998 (S.I. 1998 No. 2306), EN795:2012, The Lifting Operations and Lifting Equipment Regulations 1998 (S.I. 1998 No. 2307). The safety regulations of the respective country for using manual lifting equipment must be strictly adhered to.

INSPECTION/MAINTENANCE

Regular Inspections

To ensure that the structure remains in safe working order it must be subjected to thorough periodic inspections by a competent person. Inspections are to be 6 monthly if used for the lifting of persons or 12 monthly otherwise, unless adverse working conditions or profile of use dictate shorter periods. The components of the structure are to be inspected for damage, wear, corrosion or other irregularities. To check for worn parts it may be necessary to disassemble the structure. Particular attention should be paid to the areas of the structure described under Inspection Prior to Initial Operation - page 4.

Repairs should only be carried out by an approved specialist workshop that uses original spare parts. It is recommended that once inspected the device is marked with the date of next inspection.

Inspections are instigated by the user. If detailed information is required on inspection and test criteria, please refer to your supplier's technical department.

Please refer to page 19 for the equipment Inspection Record.

If using the davit in explosive atmospheres see additional section titled ATEX - page 9.

Maintenance/Repair

In order to ensure correct operation, not only the operating instructions, but also the conditions for inspection and maintenance must be complied with. If defects are found **stop** using the davit immediately.

No alterations or additions to the equipment should be made without the written consent of the manufacturer. Any repair shall only be carried out in accordance with the manufacturer's procedures.

It is recommended to maintain the equipment in a clean and dry manner. Cleaning is suggested using a sponge or cloth with warm, soapy water (using diluted domestic washing up liquid), rinsing and allowing to dry.

The majority of the structure is constructed from aluminium with steel fasteners; non-metallic parts are constructed from acetal co-polymers, polyethylene and polyester.

Storage and Transportation

The *PORTA-DAVIT 500* and its accessories are to be stored and transported in the bags provided.

When transporting the components the user must take note of the manual handling considerations.

SOCKETS

The *PORTA-DAVIT 500* structure needs to be anchored to a surface/foundation capable of withstanding the applicable loading. The davit can be supplied with one of the sockets specified below (**only sockets supplied by REID Lifting are approved to be used with the *PORTA-DAVIT 500***):



Top Mount



Side Mount



Bridge Mount



Cast & Resin Bonded

- The **Top Mount** socket is for use on flat horizontal surfaces. It can be installed onto concrete using resin bonded anchors or into steel work using bolts
- The **Side Mount** socket can be installed using resin bonded anchors or mechanical anchors
- The **Bridge Mount** socket is for mounting into steel work and walkways
- The **Cast & Resin Bonded** sockets can be cast into new concrete or resin bonded into existing concrete

Socket Installation

Depending upon the socket type there are multiple ways that installation can be achieved. When using bolts they are to be minimum grade 8.8 BZP or if stainless, grade A4 or equivalent.

When installing the socket it is important to ensure that the top face is as level as possible, with installation being not more than 3 degrees misaligned from the horizontal.

Socket installation should only be carried out by a competent person. If specifying the anchors, resin, fasteners or any combination of the afore-mentioned, it is essential that the competent person is of ability to specify an installation that is safe for use. If in any doubt about the calculation of loads contact your REID Lifting representative.

No. 1 in lightweight, portable, safe lifting solutions

Verifying the Installation

REID Lifting strongly recommends testing the installation of the socket before initial use; especially when using resin bonded anchors.

When verifying the installation we recommend that it is tested to a maximum force of 6kN at the device's maximum radius, if used for the lifting of personnel. If only used for the lifting of goods, we recommend testing to no greater than 125% of the goods' WLL at its maximum radius. All tests should be carried out in all anticipated worst case loading directions, sustained for a duration of 3 minutes.

If unable to test the installation as a whole, then each anchor can be isolated and tested individually applying the applicable loading, i.e. tension and/or shear loads. For clarification on the loads contact your equipment supplier.

If an installation differs from the sockets referred to above, or to that specified by your supplier then the competent person must verify by calculation that the installation can withstand the following:

- For personnel, 12kN at the device's maximum radius in all anticipated worst case loading directions **but not test to more than 6kN at the device's maximum radius**
- For lifting of goods, 150% of the goods' WLL at the device's maximum radius in all anticipated worst case loading directions **but not test to more than 125% of the goods' WLL at the devices maximum radius**

If required a sacrificial anchor may need to be installed to verify the installation has the ultimate capacities required.

Following initial socket installation verification tests we do not recommend overload tests for the socket or davit and suggest thorough visual examination only. If the client feels that as a result of a visual examination that a load test is appropriate, we would recommend a 100% load test and certainly no greater than 125%.

MARKING

The serial labels indicate:

- The product description
- The product identification number
- The product's unique serial number
- The goods' working load limit (WLL) of the device
- The year of manufacture
- The standards to which the device is approved **(only applicable when rated for the lifting of persons)**
- The ATEX rating of the product (if applicable) - see ATEX section
- CE 0088: CE mark plus notified body number (currently LRQA) who are responsible for monitoring REID Lifting's quality control system in accordance with Module D of the PPE Regulation **(only applicable when rated for the lifting of persons otherwise CE just stated)**



Read
Assembly & Operation instructions.



PORTA-DAVIT 500
Assembly & Operation instructions.

ATEX:



This product has been designed for use in explosive atmospheres. If the product is to be used in explosive atmospheres then the following section must be followed. Any different or exceeding use is considered incorrect and REID Lifting Ltd will not accept any responsibility for damages resulting from false application. The risk is solely with the user. If the product has been customised in any way then it may not comply with standards and not be suitable for use in explosive atmospheres. If this is the case then the product will not have any of the below marking. If in doubt contact your REID representative.

ATEX - Classification

If identified with the Marking below, the product meets the requirements of Category 3 equipment for use in Zone 2 explosive atmospheres, providing a normal level of protection where mixtures of air and gases, vapours or mists or by air/dust mixtures are unlikely to occur or, if they do occur, are likely to do so only infrequently and for a short period only.

Or

Available as an upgrade the product can be supplied to meet the requirements of category 2 equipment for use in Zone 1 explosive atmospheres, providing a high level of protection where mixtures of air and gases, vapours or mists or by air/dusts mixtures are likely to occur.

N.B. Sockets form an integral part of the davit system and should therefore be suitable for use in the indented environment.

ATEX - Identification

In addition to the previous Marking section, if suitable for use in explosive atmospheres, the product will have the following identification on the serial label:

As standard for Zone 2 Environments:

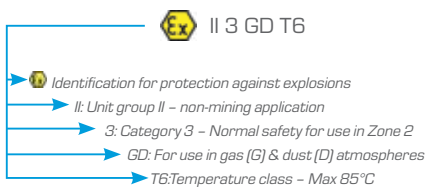

Or

As an upgrade for use in Zone 1 Environments:

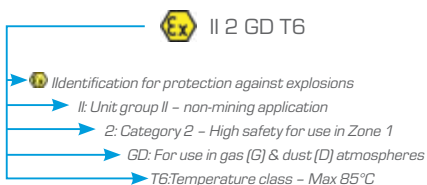

ATEX - Spark Formation

Increased danger of ignition may emanate from clashing of special material pairings. These are non-corrosion resistant steel or cast iron against aluminium, magnesium or pertinent alloys. This applies especially in case of rust or surface rust.

When assembling the product and inserting fastening components; they must be clear of rust and debris of any kind. Care must be taken to ensure the product is handled in a suitable manner and is never thrown, and always placed, onto the ground.

ATEX - Static Electricity

For Zone 1 and 2 applications static electricity has been identified as potential for build-up, leading to an incendive spark. Although the risk of such ignition is unlikely, the structure must have a clear route to earth, which must be considered when installing the sockets for mounting the structure. These sockets should be in direct contact with the ground and there should be no membrane separating the socket from the ground.

If an isolating membrane is to be used, an earthing path must be provided. If the structure is to be used in a larger socket with a nylon sleeve the davit will have to be earthed using a 4mm earthing cable attached to a convenient location on a metallic part of the structure.

No. 1 in lightweight, portable, safe lifting solutions

ATEX - Inspection, Maintenance & Repair

If using the davit in explosive atmospheres, in addition to the Regular Inspection/Maintenance information found on page 7, these additional instructions should be followed.

Inspections shall be instigated by the user and occur at least 6 monthly or sooner if adverse operating conditions or profile of use dictate shorter periods. Inspections and maintenance shall be carried out at a safe distance away from an explosive atmosphere.

Special attention should be given to dust deposits on the structure, especially in areas where the profiles come into contact and should be wiped clean and care taken not to apply materials that could create electrostatic charging. Additionally the kingpin should be checked to ensure it rotates freely and the lower bearing must be ensured to be fixed to the structure with no possibility of a build-up of debris between the contact surfaces.

The structure is predominantly constructed from aluminium which will not rust. However there are steel components used throughout. These are the fasteners, shackles and sockets. Where there is sign of any rust deposits on the aluminium structure it should be wiped clean as above and where there is sign of rust on a steel component, then that component should be removed from use and the structure not used until a replacement is fitted.

LANGUAGE

It is essential for the safety of the user that if this product is re-sold outside the original country of destination the reseller shall provide instructions for use, maintenance, for periodic examination and for repair in the language of the country in which the product is to be used.

ASSEMBLY INSTRUCTIONS

PORTA-DAVIT 500 - Strop Version

NB: Appropriate PPE should be worn:



Gloves



Protective footwear



Hard hat

The *PORTA-DAVIT 500* and its constituent components are described in the image below. The use of a socket extension is optional and the socket type may vary between a Top Mount, Side Mount, Bridge Mount, Cast In or Resin Bonded, depending on application.

N.B. No tools are required for assembly.

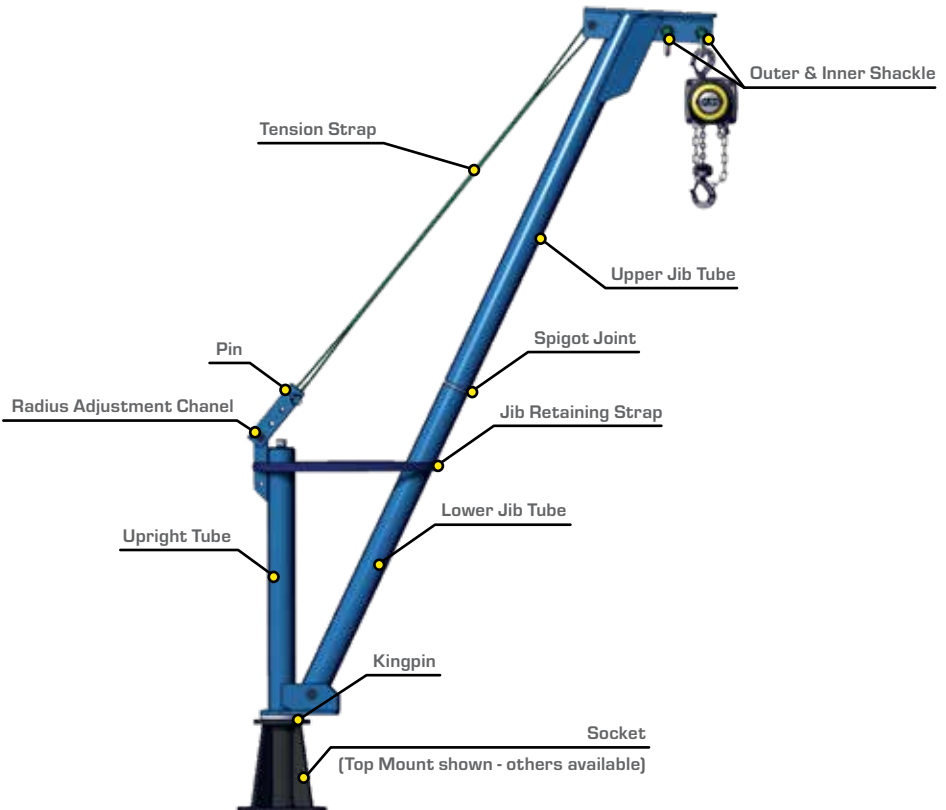

PORTA-DAVIT™ 500

No. 1 in lightweight, portable, safe lifting solutions

PORTA-DAVIT 500 - Standard



1. Insert the kingpin of the davit base assembly into the socket.

N.B. Fits all REID Lifting socket types: flush mount, top mount, side mount, bridge mount and the *PORTA-BASE*. Demonstrated using a top mount socket.

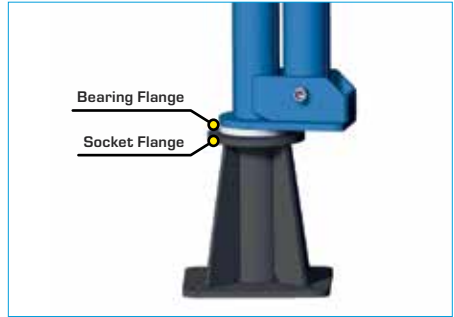

2. Ensure kingpin is fully inserted and the bearing flange is in full contact with the socket flange.



3. Loosen the retaining strap and slowly lower the lower jib tube until it is resting on the strap.



4. Supporting the weight of the upper jib on the shoulder, inset spigot into the lower jib tube.



5. Attach chain block to the shackles.



6. Supporting the weight of the jib with the shoulder, select required operating radius and attach tension strap to adjust channel with the adjustment pin.



7. Insert retaining clip through adjustment pin.

N.B. The adjustment channel may be colour coded. If the davit is being used with a *PORTA-BASE* mobile socket the pin must be inserted within the yellow zone which gives a maximum operating radius of 1000mm. If used with fixed sockets any adjustment position can be used giving up to 1200mm radius.



8. Check the davit assembly for ease of rotation.

PORTA-DAVIT™ 500

No. 1 in lightweight, portable, safe lifting solutions

PORTA-DAVIT 500W - Winched

The winched option version of the davit has a rigid adjustment channel, with winch plate mounting, which replaces the tension strap on the standard unit and a sheave block, which is attached to the davit head. The PORTA-DAVIT 500W winch version is supplied in two bags.

N.B. Only PORTA-DAVIT 500W units with a yellow adjustment channel are suitable for use with a PORTA-BASE mobile socket.



1. Follow steps 1-4 of the PORTA-DAVIT 500 standard version.



2. Remove retaining pins and clips then feed winch rope (hook end) over sheaves. The winch should **not** be attached at this point.



3. Ensure winch rope is located in sheave groove and replace retaining pins and clips.



4. Supporting the weight of the upper jib with the shoulder, raise into required operating position.

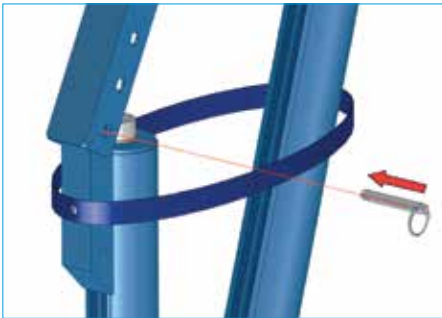

5. Attach rigid adjustment channel to davit base with adjustment pin.



6. Insert retaining clip through adjustment pin.



7. Position winch on rigid adjustment channel and attach winch with retaining pins and clips. Ensure winch rope is wound correctly.



N.B. Please read operating instructions for the winch before use.

No. 1 in lightweight, portable, safe lifting solutions

OTHER VARIATIONS

PORTA-DAVIT 350EX - Extended Operating Radius

The extended operating radius variants of the davit have two different components to the standard PORTA-DAVIT 500 – a jib extension piece and an extended adjustment channel.

Follow steps 1 -3 and then as follows:

- Attach extended adjustment channel to upright tube using securing pin and R-clip.
- Insert the spigot of the jib extension piece into the lower jib tube.
- Continue from step 4

The extended adjustment channel must only be used in conjunction with a jib extension piece.

N.B. PORTA-DAVIT 350EX or other extended davits must not be used with a PORTA-BASE mobile socket and must also not be used for personnel lifting or fall arrest applications.

PORTA-DAVIT plus Socket Extension Assembly

The assembly process can generally be performed in two ways (Method A or Method B) depending on the height of the socket extension, socket used and whether there are any hazards adjacent to the socket position.

A risk assessment should be performed before starting the process, as the local situation needs to be carefully considered.

Method A - 2 People (Recommended)

1. Assemble PORTA-DAVIT 500 or PORTA-DAVIT 350EX on the floor horizontally adjacent to the fixed socket position, and attach the chain block and slave chain to the shackles
2. Move jib arm in line with upright tube and tighten the retaining strap
3. Fit the socket extension to the davit kingpin so that the assembly is complete on the floor
4. Rotate the davit & socket extension assembly into a vertical position adjacent to the fixed socket
5. Two people should lift the davit & socket extension assembly, each using the socket handles with one hand and bracing against the davit with the other. Then insert the socket extension kingpin into the fixed socket

N.B. The davit + socket extension with chain block + slave chain weigh approximately 50kg.

6. With a shoulder against the lower jib tube, the retaining strap is released to its full extent and the davit arm allowed to rotate to full/set radius
7. The unit is now ready to be rotated into position to connect to the item to be lifted

N.B. If the fixed sockets are installed flush with ground level then the assembled unit can be "walked up" into position. The kingpin should be positioned and retained above the fixed socket when raising, so it naturally slides into the socket).

Method B - 2 people (only for Socket Extension 500mm)

1. Insert Socket Extension into socket
2. Assemble *PORTA-DAVIT 500* or *PORTA-DAVIT 350EX* on the floor horizontally adjacent to the fixed socket position, and attach the chain block and slave chain to the shackles
3. Move jib arm in line with upright tube and tighten the retaining strap
4. Rotate the davit into a vertical position adjacent to the socket
5. Two people should lift the davit assembly 500mm and insert the kingpin into the Socket Extension (the extended davit with chain block weighs 35kg)
6. With a shoulder against the lower jib tube, the retaining strap is released to full extent and the davit arm allowed to rotate to full radius
7. The unit is now ready to be rotated into position to connect the item to be lifted



QUALITY & SAFETY

ACCREDITATIONS

Quality and safety are key themes throughout this document and the REID Lifting ethos. It is with this in mind that we have undertaken external accreditations to ensure we stay focused on what is important to our clients and users, and ahead of market trends and developments.

REID Lifting is continuously audited by Lloyds Register Quality Assurance (LRQA) (CE body no. 0088) for approval of its Integrated Management System combining quality systems management, environmental issues and the health and safety practices within the company.

- **ISO 9001:2015** - Specifies requirements for a quality management system for any organisation that needs to demonstrate its ability to consistently provide products that meet customer and applicable regulatory requirements and aims to enhance customer satisfaction.
- **ISO 14001:2015** - Specifies the requirements for implementing environmental management systems throughout all areas of the company.
- **OHSAS 18001:2007** - Occupational health and safety management system.
- **LEEA Membership** - REID Lifting is a full member of the Lifting Equipment Engineers Association (LEEA membership 000897). REID Lifting conforms to the main aims of the association which is to achieve the highest standards of quality and integrity in the operations of members. Entry qualifications are demanding and strictly enforced through technical audits based on the Technical Requirements for Members.
- **IRATA** - REID Lifting is an associate member of the Industrial Rope Access Trade Association (IRATA International membership number 148). REID Lifting works in accordance with the IRATA Code of Practice, by doing so, contributes to promote the development of safe systems.

Conformité Européenne (CE)

REID Lifting's products have been designed, tested and approved (as appropriate) by the Conformité Européenne. This certifies that REID Lifting's products meet the demands of the European Directives and Regulations regarding health and safety requirements. The EC type-examination for this device has been carried out by SGS United Kingdom Ltd, 202b, Worle Parkway, Weston-super-Mare, BS22 6WA, United Kingdom (CE body no.0120) in accordance with Module B of the PPE Regulation. The EC quality assurance system for this device has been carried out by Lloyd's Register Quality Assurance Limited, 1, Trinity Park, Bickenhill Lane, Birmingham B37 7ES, United Kingdom (CE body no. 0088) in accordance with Module D PPE Regulation (EU) 2016/425.

The Queen's Award for Enterprise

REID Lifting has been awarded this prestigious award on four occasions for design, development and sale of lightweight, portable and safe lifting solutions.



- Innovation category 2006 and 2013
- International Trade 2013 and 2018

TESTING

Testing and Technical File review are integral parts of our design and manufacturing process.

External verification of products is undertaken where appropriate, using government approved Notified Bodies.

All products have been thoroughly type tested at UKAS accredited laboratories. Each system is supplied with a certificate of conformance and individual record of thorough examination or test.

Full product design and development Technical Files are available for inspection.

PRODUCT IPR

Intellectual property rights apply to all REID Lifting Ltd products. **There are patents in place, or pending, for:**

PORTA-GANTRY | PORTA-GANTRY RAPIDE | PORTA-DAVIT QUANTUM | T-DAVIT

All product names are trade-marks of REID Lifting Ltd:

PORTA-GANTRY | PORTA-GANTRY RAPIDE | PORTA-DAVIT | PORTA-BASE | T-DAVIT | PORTA-QUAD

E&OE



INSPECTION



INSPECTION RECORD

Unit 1 Wynolens, Newhouse Farm Industrial Estate, Chepstow, Monmouthshire, UK, NP16 6UD www.reidlifting.com +44 (0)1291 620 796		
Product No.:	XXXXXXXX	A
Serial Number:	XX XX XXXXX	B
WLL:	XXXX kg GOODS	C
Year of Manufacture:	20xx	D
Standards:	EN795:2012*	
ATEX:	II 3 GD T6	
*For max 150kg one person lifting / fall arrest only 		

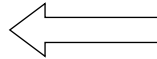

* Insert data from serial numbers found on product into table below

Product number(s)* A			
Serial number(s)* B			
WLL* C			
Year of manufacture* D			
Name of user			
Date of purchase			
Date of first use			
Periodic Examination and Repair History			
Date	Inspected by	Pass/Fail	Comments



 +44 (0)1291 620796

 sales@reidlifting.com

 www.reidlifting.com

UK

REID Lifting

Unit 1 Wyview, Newhouse Farm Ind. Estate,
Chepstow, Monmouthshire, NP16 6UD, UK

 +44 (0)1291 620 796

 +44 (0)1291 626 490

 enquiries@reidlifting.com

 www.reidlifting.com

SWEDEN

2LIFT AB

C / O JJ-Group AB

Tryckarevägen 10

434 37 Kungsbacka SWEDEN

 +46 (0)7342 26155

 info.2lift@jjgruppen.se

 www.jjgruppen.se

ITALY

F.A.S. S.p.A.

Via dei Lavoratori 118/120

20092 Cinisello Balsamo ITALY

 +39 (0)2612 4951

 s.scarpetta@fasitaly.com

 www.fasitaly.com

USA

Thern, Inc.

5712 Industrial Park Road

PO Box 347, Winona, MN 55987, USA

 +1 507 454 2996

 +1 507 454 5282

 info@thern.com

 www.thern.com

FRANCE

REID Lifting France

P.A. de Kerboulard, Rue Gutenberg

56250 Saint-Nolf FRANCE

 +33 (0)297 53 32 99

 +33 (0)297 53 04 86

 contact@reidlifting.fr

 www.reidlifting.fr

DE & AUT & CH

REID Lifting D-A-CH

Finkenstrasse 26

8280 Kreuzlingen SWITZERLAND

 +41 (0)71 686 90 40

 +41 (0)71 688 51 69

 jesser@reidlifting.de

 www.ecolistec.ch

 www.reidlifting.de

AUSTRALIA

Vector Lifting

43 Spencer Street

Jandakot, WA 6164 AUSTRALIA

 +61 (0)8 9417 9128

 +61 (0)8 9417 4105

 info@vectorlifting.com.au

 www.vectorlifting.com.au

CANADA

Equipment Corps Inc.

1256 Arvin Avenue, Stoney Creek

On L8E 0H7 CANADA

 +1 905 545 1234

 +1 905 545 1270

 sales@equipmentcorps.com

 www.equipmentcorps.com

