

# pewag winner lifting clamps

## Lifting

Product Distributed in Ireland by:



601, Western Industrial Estate,  
Dublin 12, Ireland T: + 353 (0)1  
4584836 E: [sales@prolift.ie](mailto:sales@prolift.ie)

[www.prolift.ie](http://www.prolift.ie)



**Our products overcome  
any challenge.**



# Content

## pewag winner lifting clamp range

pewag lifting clamps, manufactured to the highest quality standards, are the perfect addition to the pewag winner range of hoist chains and significantly extend its area of application.

<b>Content</b>	<b>3</b>
----------------	----------

### **pewag group**

Welcome to the pewag group	4-5
History, Quality management	6
Business areas, Environment	7
Customer proximity	8

### **pewag winner lifting clamps**

Benefits and informations, user information	10-13
pewag winner vertical lifting clamps	14-26
pewag winner vertical lifting clamps extra-hard	27
pewag winner horizontal lifting clamps	28-35
pewag winner screw clamps	36-41
pewag winner drum clamps	42-45
pewag winner special clamps and grabs	46-51

### **pewag winner lifting clamps spare parts**

pewag winner clamp components – spare parts	52-55
Risk-free lifting	56-57

# Welcome to the pewag group

**We are an internationally operating group of companies. Our track record goes back to the year 1479.**

## Mission Statement

### pewag group's Mission Statement

**expresses the goals of our actions as follows:**

With our joy for innovation, we ensure that all products of the pewag group are the best in the respective markets, both now and in the future. The high quality of our products and services as well as our employees' passionate dedication are the foundation to our pursuit of outstanding services and complete customer satisfaction.

## Principles of pewag group

### Leading in Quality

The values of our premium product brands are demonstrated by our first class quality and innovations and are communicated consistently and coherently.

We anticipate market demands and changes in the environment and adapt our strategies, organizations and actions accordingly to satisfy our customers' needs through providing the best value for the money; timely delivery; efficient and obliging service.

### Leading in Responsibility

We commit ourselves to careful treatment of the environment, by reducing the use of energy and raw materials, ensuring the longevity of our products and making them recyclable.

We value an open, honest and team-oriented work-style, which is based on transparent communication honoring ideas, opinions and experience of our employees as valuable inputs for our decision making process.

We strive for stable and fair partnerships with our employees, customers, suppliers and other business partners and take social aspects into consideration when making business decisions.

### Leading in Technology

We secure our technological leadership through highest product quality, constant improvements and innovations of products, as well as manufacturing processes.

We are dedicated to keep on top of product technology. This ensures that our customers always have the best solutions available and that we expand and protect our market position.

### Leading in Economics

In all our processes we use due diligent business practices and efficiency and strive to improve these continuously.

In the long-term, we will continuously increase our economic performance to raise corporate value, achieve sustained growth and thus secure a successful future of the organization.

We are a modern group of companies which looks back to a tradition and experience of more than 500 years. Since our founding years, a lot has changed, but the values that made our success possible from the beginning remain.

**pewag group –  
Innovation. Quality. Partnership.**

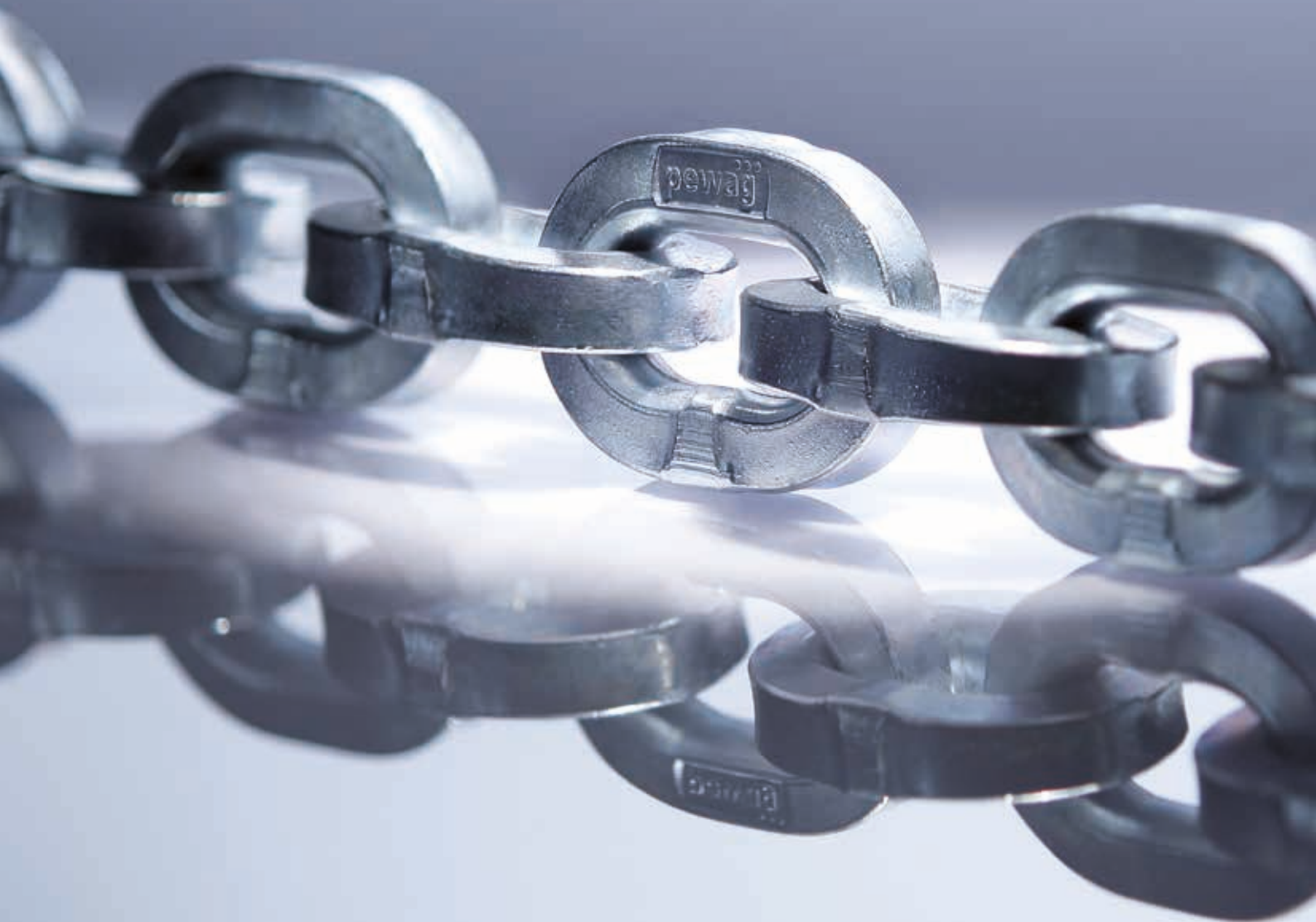

# History of the pewag group

# Quality management

## Advantage through tradition

The history of pewag group goes back to the 15th century and therefore makes us the oldest chain manufacturer worldwide. With our experience we are ready for the future.

### Timetable of important events

- 1479** First documented references of a forging plant in Brückl
- 1787** Foundation of a chain forge in Kapfenberg
- 1803** Foundation of a chain forge in Graz
- 1836** Establishment of an iron casting plant in Brückl
- 1912** Production of the first pewag snow chain
- 1923** Merger of plants in Graz and Kapfenberg – Creation of the name “pewag”
- 1972** Foundation of a sales company in Germany
- 1975** Foundation of a sales company in the USA
- 1993** Foundation of pewag austria GmbH
- 1994** Foundation of the first subsidiary in Czech Republic
- 1999** Acquisition of the Weissenfels Group
- 2003** Separation from the Weissenfels Group
- 2005** Reorganization into 2 groups:  
Schneeketten Beteiligungs AG Group – Snow Chains  
pewag austria GmbH Group – Technical Chains
- 2009** Acquisition of Chaineries Limousines S.A.S.
- 2012** Foundation of the first manufacturing company in the USA
- 2013** Foundation of various international sales companies



Lithography forging plant Brückl 1855



Anchor chain forge 1878



Chain forgers 1956

## Our main goal is customer satisfaction.

In this instance, quality means that only those products and services are developed, manufactured and delivered which completely and without compromise satisfy the customer. The pewag group’s quality policy, is underlined by the following basic principle: **“we supply high-end products and services to our customers that conform to the technical standards and requirements”**, can be summarised in the subsequent four points.

### Market-oriented Quality

In order to maintain and to widen the competitive position of the pewag group, the quality of finished goods and services must be consistent with the specifications of the customer and also with their expectations of a technological leader. No product should ever pose a danger to people or the environment.

### Economic Quality

As a profit-oriented company, quality is achieved by taking into consideration the material, personnel and financial resources; this means that we establish an appropriate best price/performance ratio for the customer within the acknowledged framework.

### Quality Responsibility

Stringent demands are placed on all employees to ensure high standards of quality. No matter what hierarchical level, all managers are in charge of managing quality. Every employee within the pewag group should be educated, motivated and instructed by the management team. It is important for promoting high quality awareness that the education and training of employees is at the forefront, as each employee is responsible for the quality of his/her own work.

For each of our employees, the statement **“QUALITY STARTS WITH ME”** must be true!

### Process-oriented Quality

The close interaction between sales, product development, production and customer service is regulated within the individual companies by fixed processes and activities, as well as responsibilities with the aim to reach and maintain the defined quality standards.



# Business areas

# Environment – we take responsibility

## Working with pewag products

The pewag group has a substantial and diverse spectrum of products and services.

Our range of products varies from traction chains for tires (snow chains for passenger cars, trucks and special-purpose vehicles, tire protection chains for mining vehicles) over different industrial chains to products for the do-it-yourself sector (light chains, belts, etc.)



**Segment A**  
Snow and forestry chains



**Segment B**  
Hoist and conveyor chains



**Segment C**  
Do-it-yourself

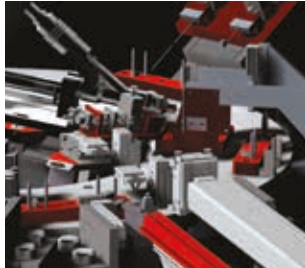

**Segment D**  
Engineering



**Segment F**  
Lifting and lashing chains and accessories



**Segment G**  
Tire protection chains

## Ecological awareness in all areas



Our company's manufacturing location in Kapfenberg, Austria, has been used for iron and steel production for over 270 years. A second facility located in Brückl, Austria, was first documented in records dating back to 1479. Based on this long

manufacturing tradition, we take serious responsibility for our products, employees and the environment at all our international locations. Hence, one of our major concerns is to improve energy efficiency and, in doing so, to minimise energy consumption over a long period of time with the development of new production technologies. An important goal is to increase energy efficiency and consequently lower energy demand. Consequently, we develop our products to achieve longer product life-cycles and lower weight but simultaneously, increasing their working load capacities and the safety for our customers. We are committed to upholding all relevant energy and environmental standards by setting clearly defined goals and continually improving our performance. To achieve this goal, we use modern manufacturing technologies. An important step is to provide the necessary resources and to include our employees in the process. We are convinced that well-informed and motivated employees can actively participate in environmental conservation.

Wherever we are unable to avoid an environmental impact, we have set ourselves the goal to continually reduce our energy consumption, waste and environmentally harmful emissions. When purchasing new equipment, we strive to find the best and most efficient technical solution possible. It is important for us to promote the purchase of energy efficient products and services.

Our process-oriented management system regulates the documentation concerning all environmental relevant procedures. It also encompasses preventative measures for possible failures, as well as behavioural instructions for regular and/or extraordinary operational procedures. By systematically monitoring and assessing our environmental activities, we are quickly able to resolve deviances and to take corrective action. This process extends throughout the whole organisation to optimise all business processes. We strive to engage in an open dialogue with our customers, neighbours and authorities to inform them of our energy and environmental engagements.

Through specific communication we want to inform our customers about the environmental aspects of our products – specifically inform them about the longevity of our products. Through meaningful communication, we strive to motivate our suppliers and customers to think – in turn – about their environmental footprint and to put into practice similar environmental standards in their businesses.

# Customer proximity

## International presence

In the ambitious five-hundred year history pewag has evolved from a small and modest company to a global organization with several subgroups.

With 11 production and 31 sales and other locations on the continents of Europe, America, Africa and Australia pewag documented its claim as the world's number one chain manufacturer.

In addition to the numerous locations pewag as an international company relies on his capillary, strong, and professional partner network. These collaborations provide optimal customer service in currently more than 100 countries around the world.

## Production and sales locations

### Europe

Austria	pewag austria GmbH, Graz pewag austria GmbH, Kapfenberg pewag Schneeketten GmbH & Co KG, Graz pewag Schneeketten GmbH & Co KG, Brückl pewag engineering GmbH, Kapfenberg pewag austria Vertriebsgesellschaft mbH, Graz pewag Ketten GmbH, Klagenfurt pewag International GmbH, Klagenfurt
Germany	pewag Deutschland GmbH, Unna pewag Schneeketten Deutschland GmbH, Unna
France	pewag France SAS, Èchirolles/Grenoble Chaineries Limousines SAS, Bellac Chaineries Limousines SAS, Limoges
Italy	pewag italia srl, Andrian Acciaierie Valcanale Srl, Tarvisio
The Netherlands	pewag nederland BV, Hillegom APEX International BV, Hillegom
Poland	pewag polska Sp z o.o., Buczkowice
Portugal	pewag Portugal, Santo Antão do Tojal
Russia	OOO „PEWAG“, Moscow OOO „pewag russia“, Moscow
Kazakhstan	Representative office of pewag international GmbH, Almaty
Croatia	pewag croatia doo, Zagreb
Sweden	pewag sweden AB, Emmaboda

### Europe

Slovakia	pewag slovakia sro, Nitra
Czech Republic	pewag Snow Chains s.r.o., Vamberk pewag sro, Vamberk KOMAP Dědov sro, Dědov KOMAP Dědov sro, Chrudim
Ukraine	TOV pewag Ukraine, Lviv

### North America

USA	pewag Inc, Bolingbrook, Illinois pewag Inc, Rocklin, California pewag Traction Chain Inc, Pueblo
Mexico	pewag Mexico S.A. de C.V., Mexico

### South America

Brazil	pewag Brasil Comércio de Correntes Ltda., São Paulo
--------	---

### Africa

South Africa	pewag chain south africa (pty) ltd., Rivonia HMV Engineering (Pty) Ltd, Houghton Johannesburg
--------------	---

### Australia

Australia	pewag australia Pty Limited, Barrack Heights
-----------	--



pewag group presents  
itself on the internet. More ...  
[www.pewag-group.com](http://www.pewag-group.com)  
[www.pewag.com](http://www.pewag.com)

**pewag group –  
Innovation. Quality. Partnership.**



# pewag winner lifting clamps

## Benefits and Information

Content 10

### pewag winner lifting clamps

Benefits and informations 12

User information 12-13

Warranty 13

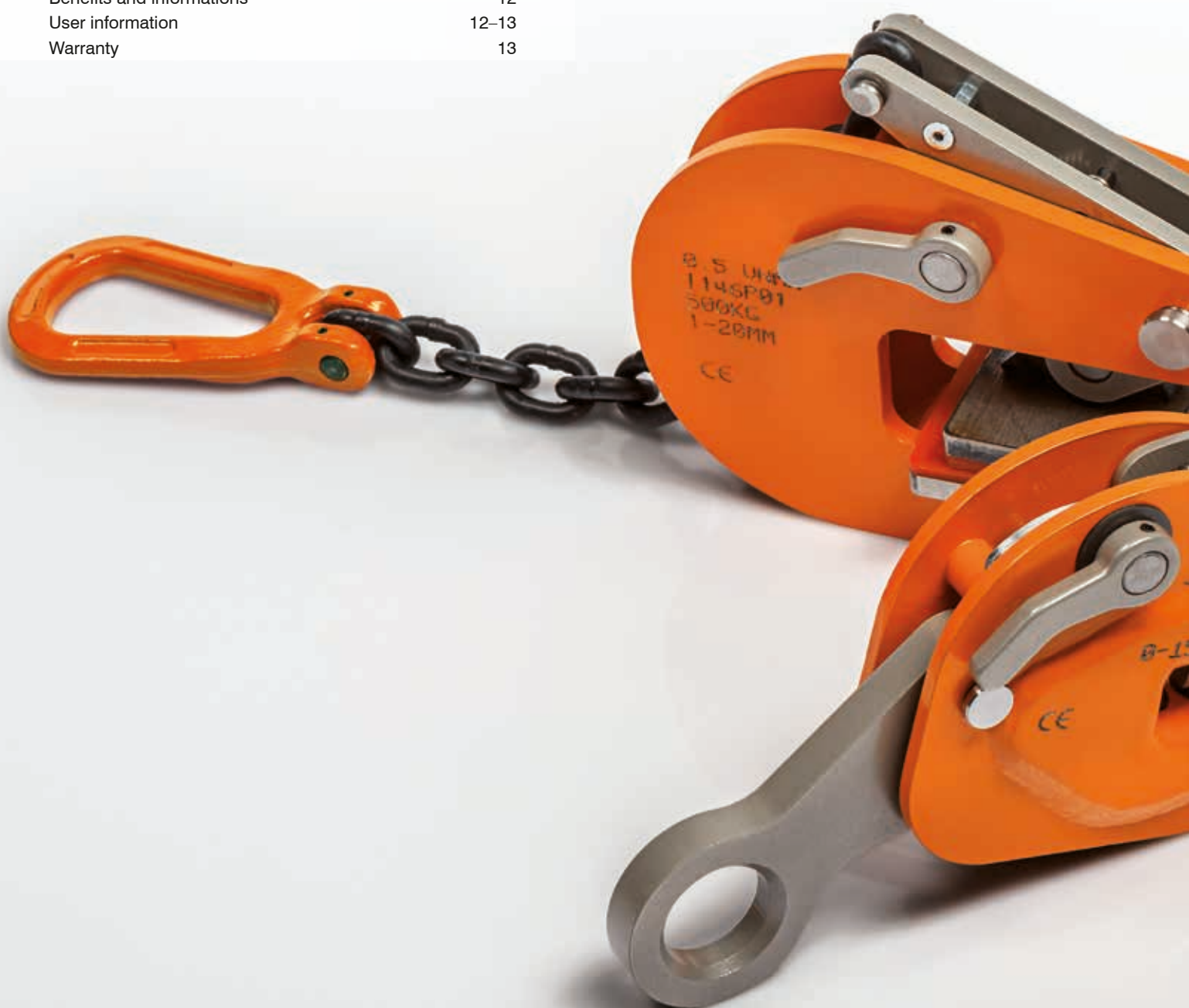



# Benefits and information

## Benefits and information on the pewag lifting clamp system

- Production relies on state-of-the-art machines that work to a consistently high standard
- Innovation is at the centre of the development and production process of pewag lifting clamps
- We continuously improve our products and always strive to find new solutions
- User-friendly and safe application is key
- Broad product range for a multitude of applications

## Design

- Light, streamlined design for easy handling
- Easy maintenance
- High resilience and long lifespan thanks to premium-quality steel
- Compliance with all standards and regulations, such as European standard EN 13155, Australian standard 4991, North American standard ASME B30.20-2010 and European Machine Directive 2006/42/EC

## Quality

- Quality-assured European manufacturing in ISO 9001-certified production sites
- Excellent quality and processing
- Use of special steels
- Thought-out construction, easy to repair
- All lifting clamps are tested to up to twice the maximum load capacity in our dedicated testing facilities
- Each clamp is delivered with its own test certificate
- The break factor of pewag lifting clamps lies at five times the load capacity

# User information

## User information for use, storage, inspection and maintenance of pewag safety lifting clamps

## General information

pewag lifting clamps may be used for general lifting applications and are compatible with a wide range of designs, loads and attachments. Please see our catalogue for information on design and load capacities.

The different lifting clamps are designed for specific areas of application and it is therefore important that users are aware of all operating conditions. Please contact our technical service team in case of issues or questions. pewag lifting clamps may only be used by a qualified person. If used correctly, pewag lifting chains have a long lifespan and offer a high level of safety. Material or personal damage may only be prevented if the lifting clamps are used correctly. Reading and understanding our user information is an essential prerequisite for using our lifting clamps, but can never replace the responsible, provident handling of all lifting processes.

## Modifications of the condition upon delivery

The original condition of the pewag lifting clamp must not be altered in any way, for instance by bending, grinding, removal of parts, welding, application of drillings, stamps etc. Do not remove any parts from the clamps (for instance bolts, safety pins, springs etc.) Surface treatments such as hot-dip galvanising and electrogalvanising are not suitable for pewag lifting clamps. Chemical stripping or alkaline-based stripping are also hazardous processes that need to be discussed with pewag in advance. Please contact our technical service if you have any questions.

## Use of pewag lifting clamps

Always read the instructions before using a pewag lifting clamp. Our standard lifting clamps are suitable for lifting and transporting steel plates with a maximum hardness of 37 Hrc (345 HB). For materials with a hardness of up to 50 Hrc (485 HB), we supply clamps where the tooth ring and the tooth segment have been additionally hardened – see model “Extra-Hard” (H). Our standard lifting clamps have a minimum load capacity of 10% of the maximum load capacity as indicated on the clamp housing.

For weights below the 10% limit of the maximum load capacity, we recommend the VJPW and VJPUW clamps without a minimum load capacity limit. Never overload a clamp and take care to avoid loads being lifted suddenly or the clamp bumping against an obstacle.

Always use the entire gripping depth of the clamp. Never lift more than one plate at a time, except with models that are designed to lift several plates (for instance the HSKW models). Always keep a safe distance when lifting or lowering a load and do not allow anyone to stand underneath the load. pewag lifting clamps must be stored clean and dried and protected against corrosion.

## Restrictions on the use of pewag lifting clamps

The following restrictions on the use of pewag lifting clamps due to adverse environmental conditions and/or hazardous circumstances apply:

### Influences resulting from temperature

pewag lifting clamps are designed to be used in normal atmos-

pheric conditions and in a temperature range from -40°C to +100°C. The clamps must not be used if these conditions are not met.

#### Influences from acids/alkalines and chemicals

pewag lifting clamps must not be exposed to acids/alkalines or their vapours.

**Note:** Certain production methods may release acids and/or vapours!

#### Hazardous circumstances

The load capacity categories in this catalogue are based on the assumption that no hazardous circumstances apply. Such circumstances include offshore use, the lifting of persons or of potentially hazardous loads such as liquid metals, corrosive substances or nuclear material. In any of these cases, the hazard level must be assessed by an expert and the load capacity adjusted accordingly.

#### Inspections

Prior to the first use of a lifting clamp, the following checklist applies:

- The lifting clamp is the one ordered
- The test certificate and/or factory certification is present
- The labelling and load capacity information on the lifting clamp is identical with the information provided in the test certificate and/or factory certification
- The instructions for use of the lifting clamp are present and have been read and understood by all users

#### Damages

The lifting clamps must be checked for obvious damage and wear and tear before each use. If in doubt, the lifting clamp should not be used and must be inspected by an expert before re-use.

If any form of wear and tear and/or damage is found, the following procedure applies:

1. Decommission the clamp (note down date of decommissioning)

2. Try to determine the reason for the fault,

e.g. (see instructions for use for a detailed checklist):

- Overload
- Inappropriate use (such as pulling or dragging objects)
- Negligent and careless use

Please note that such damages are not covered by the warranty!

To protect your personal safety and that of your colleagues, please follow these steps:

3. Hand the lifting clamp over to an authorised pewag service point together with the service record

4. The lifting clamp may be used again after the revision/repair process has been completed (note down date in the service record)

## Checks/Safety inspection

Please see the instructions for use of your pewag lifting clamp for the official schedule for inspection, maintenance and revision.

All inspections and repairs must be entered in an inspection record. This not only applies to inspections carried out by yourself, but also to those performed by an authorised pewag service point.

Any maintenance or repair work must be performed by an authorised pewag service point.

Only original pewag parts may be used for repairs of pewag lifting clamps!

Whenever the unit is handed over for inspection or repair works, the service record must be provided.

Records of the inspections performed, in particular their results and any maintenance/repair works, must be kept throughout the utilisation period of the lifting clamp.

## Warranty conditions and provisions

pewag austria GmbH grants end users a 5-year warranty for their pewag lifting clamp. This warranty only applies to the original final user of the lifting clamp and under the proviso that the lifting clamp is inspected and serviced throughout the warranty period according to the manufacturer's instructions. The warranty period is 5 years from the date of the sale. The warranty is subject to the conditions and provisions listed below:

#### Conditions and provisions:

The warranty covers only such damages which are a result of manufacturing faults and occur during normal use. Wear and tear of parts such as tooth rings, tooth segments, tension springs etc. is excluded from the warranty.

If a fault is detected during the warranty period, the lifting clamp shall be repaired or replaced at the manufacturer's discretion.

Faults that are caused by any of the following factors are excluded from the warranty:

- Normal wear and tear
- Overload
- Inappropriate or careless use
- Damage
- Non-compliance with the specified processes and measures
- Lifting of objects other than those indicated on the clamp or in the instructions of use
- Modifications / alterations of the pewag clamp
- Inexpert use of the clamp and non-compliance with the instructions of use
- Maintenance or repair works completed by other than an authorised pewag service point

The manufacturer assumes no liability for incidental damages resulting from the use of the lifting clamp or a violation of these warranty conditions.

# pewag winner vertical lifting clamps

## Product Overview

Content 14

### pewag winner vertical lifting clamps

VCW/SVCW pewag winner vertical lifting clamps	16
VMPW/VEMPW/SVMPW pewag winner vertical lifting clamps	17
VUW/VEUW/SVUW pewag winner vertical lifting clamps	18
VEUW-A pewag winner vertical lifting clamps	19
VUW-R pewag winner vertical lifting clamps	19
VHPW pewag winner vertical lifting clamps	20
VHPUW pewag winner vertical lifting clamps	21
VNMW/VSNMW pewag winner vertical lifting clamps	22
VNMAW pewag winner vertical lifting clamps	23
VJPW pewag winner vertical lifting clamps	24
BKW pewag winner vertical lifting clamps	25
OBKW pewag winner vertical lifting clamps	26
pewag winner vertical lifting clamps with an extra hardened pivot and cam (H)	27





## VCW/SVCW pewag winner vertical lifting clamps

For vertical lifting and moving of steel plates and structures. The VCW/SVCW lifting clamps are equipped with a safety mechanism, ensuring the clamp does not slip when lifting force is applied and when load is being lowered. The clamp is locked in closed as well as in open position. Lifting capacity and jaw opening are clearly engraved in the body. The SVCW types are supplied with enlarged jaw opening. Minimum W.L.L. is 10% of the maximum W.L.L.

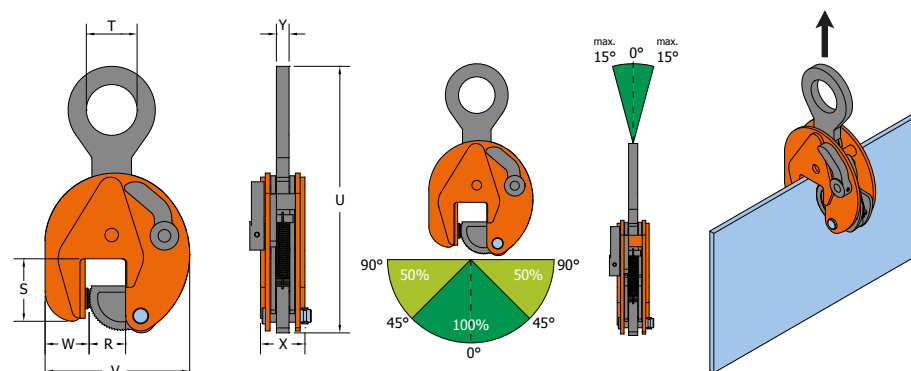

Code	Load capacity [kg]	Jaw-opening R [mm]	S [mm]	T [mm]	U [mm]	V [mm]	W [mm]	X [mm]	Y [mm]	Weight [kg/pc.]
VCW 0,75 t	750	0-13	47	30	202	100	37	37	10	1,70
VCEW 1 t	1.000	0-25	56	45	263	141	37	47	15	3,50
VCEW 2 t	2.000	0-35	78	64	336	183	56	56	16	7
VCEW 3 t	3.000	0-35	78	64	336	183	56	56	16	7
VCW 4,5 t	4.500	0-25	85	70	423	203	60	77	20	15
VCEW 4,5 t	4.500	0-45	85	70	425	228	60	78	20	16
VCW 6 t	6.000	0-32	114	75	490	225	78	78	20	19
VCEW 6 t	6.000	0-50	114	75	490	259	82	78	20	21
VCW 7,5 t	7.500	0-40	111	75	530	246	76	82	20	24
VCEW 7,5 t	7.500	0-55	111	75	522	267	70	86	20	26
VCW 9 t	9.000	0-55	111	75	522	267	70	86	20	27
VCW 12 t	12.000	0-52	148	85	617	295	100	94	44	37
VCW 15 t	15.000	0-76	209	86	810	373	136	106	49	70
VCW 17 t	17.000	0-76	209	86	810	373	136	106	49	71
VCW 20 t	20.000	0-80	250	100	933	563	153	140	66	149
VCW 25 t	25.000	5-85	250	100	925	563	148	140	66	149
VCW 30 t	30.000	10-90	250	100	918	568	153	142	66	155,50
SVCW 6 t	6.000	40-90	114	75	486	275	70	78	20	21
SVCW 7,5 t	7.500	50-100	111	75	524	312	70	86	20	26,50
SVCW 9 t	9.000	50-100	111	75	522	312	70	86	20	27,50
SVCW 12 t	12.000	50-100	152	85	615	344	100	94	44	41
SVCW 15 t	15.000	80-150	224	86	800	450	136	106	49	76
SVCW 20 t	20.000	80-150	249	100	924	640	153	140	66	160
SVCW 25 t	25.000	80-150	249	100	924	640	153	140	66	160
SVCW 30 t	30.000	80-150	249	100	906	645	156	142	66	165,50



## VMPW/VEMPW/SVMPW pewag winner vertical lifting clamps

The VMPW, VEMPW and SVMPW lifting clamps are equipped with a three way multi-purpose lifting shackle. The lifting shackle has a three way articulated linkage arrangement. For lifting and moving of all steel plates and structures. When attached to a fixed load bearing arm (e.g. spreader bar) the clamp will retain its flexibility and no chain is needed. Due to the length of the three way linkage arrangement the clamp can be lowered further between standing plates or structures. Lifting capacity and jaw opening are clearly engraved in the body. Type SVMPW is supplied with an enlarged jaw opening. Minimum W.L.L. is 10% of the maximum W.L.L.

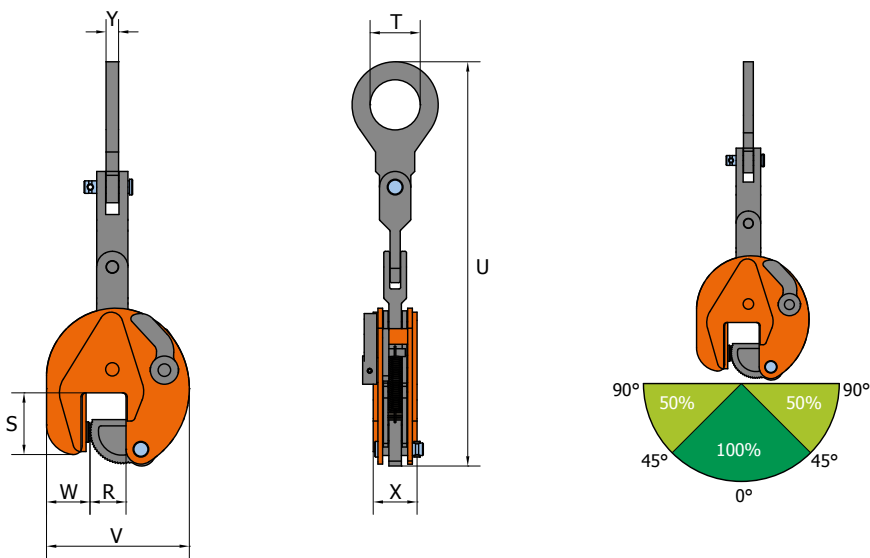

Code	Load capacity [kg]	Jaw-opening R [mm]	S [mm]	T [mm]	U [mm]	V [mm]	W [mm]	X [mm]	Y [mm]	Weight [kg/pc.]
VMPW 0,75 t	750	0-13	47	30	307	100	37	37	10	2
VEMPW 1 t	1.000	0-25	56	45	403	141	37	47	15	4,50
VEMPW 2 t	2.000	0-35	78	64	516	183	56	56	16	8
VEMPW 3 t	3.000	0-35	78	64	516	183	56	56	16	8
VMPW 4,5 t	4.500	0-25	85	70	648	203	60	77	20	17,80
VEMPW 4,5 t	4.500	0-45	85	70	650	228	60	78	20	19
VMPW 6 t	6.000	0-32	114	75	760	225	78	78	20	24
VEMPW 6 t	6.000	0-50	114	75	760	259	82	78	20	25,50
VMPW 7,5 t	7.500	0-40	111	75	800	246	76	82	20	29
VEMPW 7,5 t	7.500	0-55	111	75	792	267	70	86	20	30,50
VMPW 9 t	9.000	0-55	111	75	792	267	70	86	20	31
SVMPW 6 t	6.000	40-90	114	75	756	275	70	78	20	26
SVMPW 7,5 t	7.500	50-100	111	75	695	312	70	86	20	31,50
SVMPW 9 t	9.000	50-100	111	75	792	312	70	86	20	32,50

## VUW/VEUW/SVUW pewag winner vertical lifting clamps

Clamp-version with moveable lifting shackle for lifting and moving steel plates and structures from all positions (horizontal, vertical and sidelong). VUW/VEUW/SVUW Lifting clamps are equipped with a safety mechanism, ensuring the clamp does not slip when lifting force is applied and when load is being lowered.

The clamp is locked in closed as well as in open position.

Lifting capacity and jaw openings are clearly engraved in the body. SVUW type clamps are supplied with a larger jaw opening. Minimum W.L.L. is 10% of the maximum W.L.L.

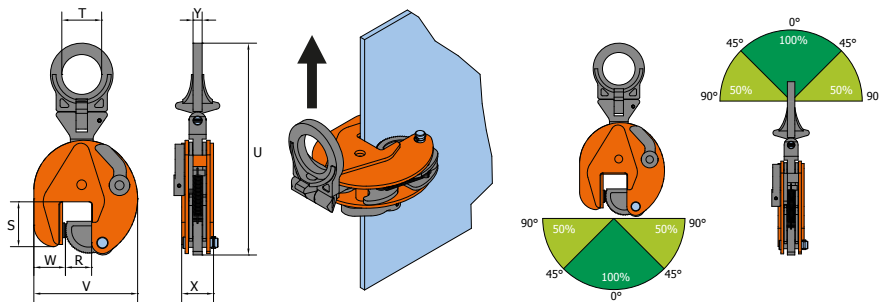

Code	Load capacity [kg]	Jaw-opening R [mm]	S [mm]	T [mm]	U [mm]	V [mm]	W [mm]	X [mm]	Y [mm]	Weight [kg/pc.]
VUW 0,75 t	750	0-13	47	30	203	100	37	37	10	1,80
VEUW 1 t	1.000	0-25	56	50	292	141	37	47	15	3,80
VEUW 2 t	2.000	0-35	78	70	372	183	56	56	16	8
VEUW 3 t	3.000	0-35	78	70	372	183	56	56	16	8
VUW 4,5 t	4.500	0-25	85	70	429	203	60	77	20	16
VEUW 4,5 t	4.500	0-45	85	70	431	228	60	78	20	16,50
VUW 6 t	6.000	0-32	114	78	528	225	78	78	32	22
VEUW 6 t	6.000	0-50	114	78	527	259	82	78	32	24
VUW 7,5 t	7.500	0-40	111	78	567	246	76	82	32	27
VEUW 7,5 t	7.500	0-55	111	78	560	267	70	86	32	28
VUW 9 t	9.000	0-55	111	78	560	267	70	86	32	29
VUW 12 t	12.000	0-52	148	85	648	295	100	94	48	41
VUW 15 t	15.000	0-76	209	85	816	373	136	106	48	73
VUW 17 t	17.000	0-76	209	85	816	373	136	106	48	74
VUW 20 t	20.000	0-80	250	100	948	563	153	140	71	160
VUW 25 t	25.000	5-85	250	100	948	563	148	140	71	160
VUW 30 t	30.000	10-90	250	100	944	568	153	142	71	167
SVUW 6 t	6.000	40-90	114	78	523	275	70	78	32	24
SVUW 7,5 t	7.500	50-100	111	78	560	312	70	86	32	30
SVUW 9 t	9.000	50-100	111	78	560	312	70	86	32	31
SVUW 12 t	12.000	50-100	152	85	644	344	100	94	48	45
SVUW 15 t	15.000	80-150	224	85	808	450	136	106	48	78
SVUW 20 t	20.000	80-150	249	100	940	640	153	140	71	171
SVUW 25 t	25.000	80-150	249	100	940	640	153	140	71	171
SVUW 30 t	30.000	80-150	249	100	946	645	156	142	71	176,50

## VEUW-A pewag winner vertical lifting clamps

Only one clamp is needed for different kind of jobs. Also the same clamp can be used if a big jaw opening is necessary. For lifting and moving of steel plates and structures from all positions. Jaw opening from 0 - 95 mm. Adjustable by steps of 30 mm. Capacity 3.000 kg. Strong and lightweight construction.

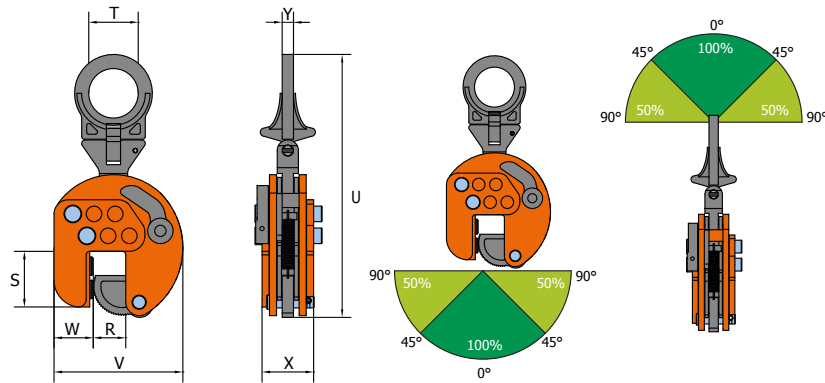

Code	Load capacity [kg]	Jaw-opening R [mm]	S [mm]	T [mm]	U [mm]	V [mm]	W [mm]	X [mm]	Y [mm]	Weight [kg/pc.]
VEUW-A 3 t	3.000	0-95	79	70	373	183-243	51	77	16	10

## VUW-R pewag winner vertical lifting clamps

For lifting and moving of stainless steel plates and structures a VUW-R lifting clamp is available. Pivot and cam are made of stainless steel. Body and lock lever are nickel plated to prevent corrosion due to carbon contamination.

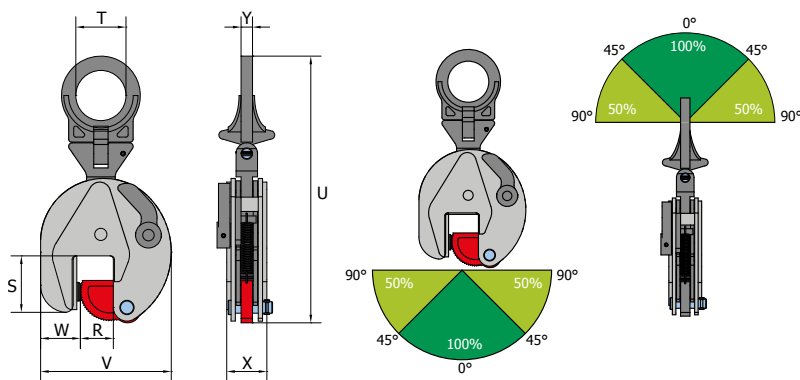

Code	Load capacity [kg]	Jaw-opening R [mm]	S [mm]	T [mm]	U [mm]	V [mm]	W [mm]	X [mm]	Y [mm]	Weight [kg/pc.]
VUW-R 2 t	2.000	0 - 20	78	70	370	165	54	56	16	7

## VHPW pewag winner vertical lifting clamps

For lifting and moving of Holland-profile (HP) steel rails and structures with HP-profiles.

Also useful as a “big-jaw” opening clamp (e.g. serving of lathes with large discs). Equipped as standard with three pivots for extra powerful clamping force.

The VHPW lifting clamps are equipped with a safety mechanism, ensuring the clamp does not slip when lifting force is applied and when load is being lowered.

The clamp is locked in closed as well as in open position.

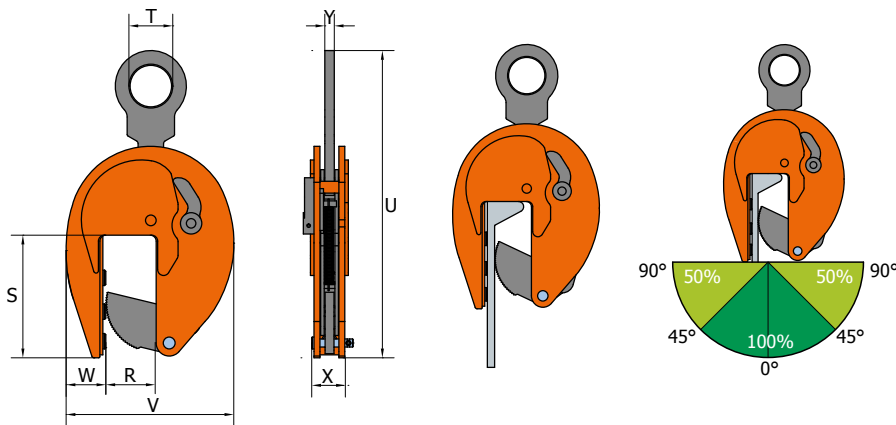

Code	Load capacity [kg]	Jaw-opening R [mm]	S [mm]	T [mm]	U [mm]	V [mm]	W [mm]	X [mm]	Y [mm]	Weight [kg/pc.]
VHPW 1 t	1.000	0-80	207	70	520	283	67	64	16	19
VHPW 1,5 t	1.500	0-80	207	70	520	283	67	64	16	19
VHPW-A 1,5 t	1.500	0-155	160	70	523	256-333	62	66	16	18

## VHPUW pewag winner vertical lifting clamps

This special version with a movable supporting ring and two tooth rings is another addition to our product range. This clamp is designed to be used for moving, lifting and lowering Holland profiles and/or construction units with built-in Holland profiles.

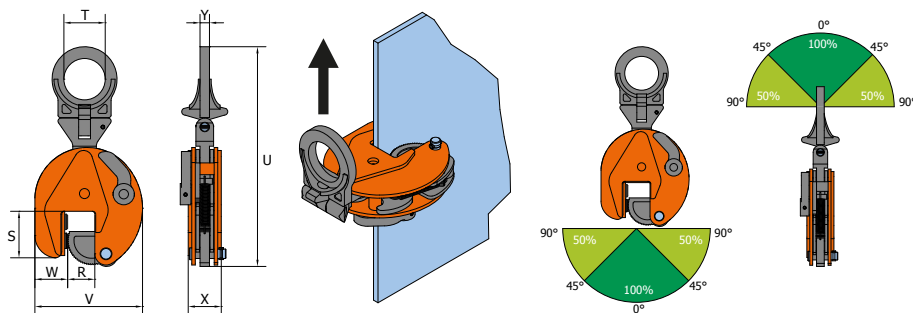

Code	Load capacity [kg]	Jaw-opening R [mm]	S [mm]	T [mm]	U [mm]	V [mm]	W [mm]	X [mm]	Y [mm]	Weight [kg/pc.]
VHPUW 3 t	3.000	0-35	93	70	369	182	58	54	16	8
VHPUW 5 t	5.000	0-45	110	70	434	228	58	86	20	17,30

## VNMW/VSNMW pewag winner vertical lifting clamps

VNMW/VSNMW pewag winner is a non-marking clamp with two special synthetic pads. The clamp can be used for lifting, handling and moving of (stainless) steel, aluminium, wood and marble plates and will not leave any marks.

The clamp is locked in closed as well as in open position and is mounted in the crane hook by means of a lifting chain with reeving link.

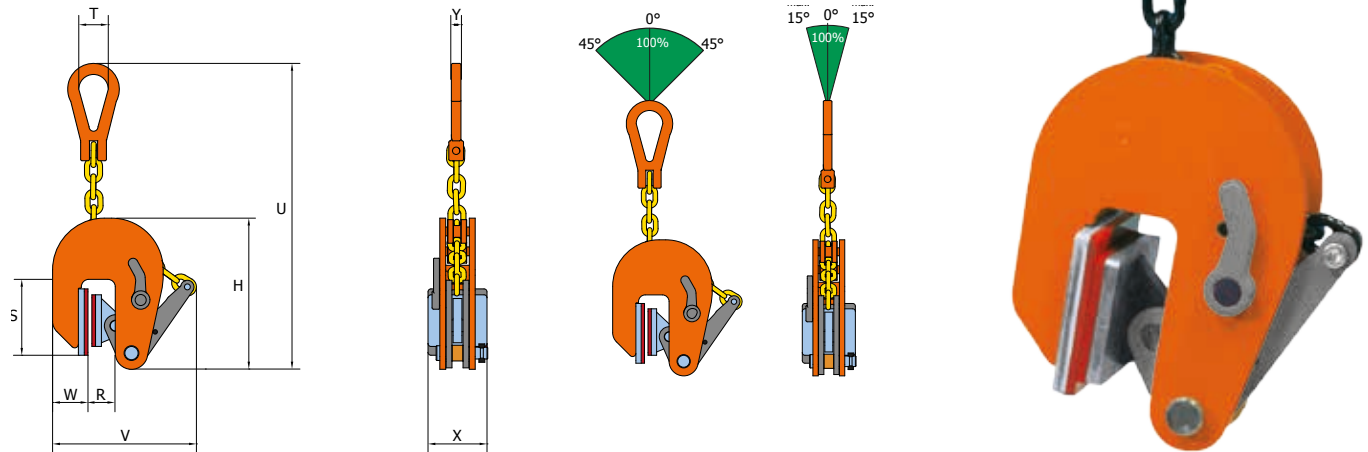

Code	Load capacity [kg]	Jaw-opening R [mm]	H [mm]	S [mm]	T [mm]	U [mm]	V [mm]	W [mm]	X [mm]	Y [mm]	Weight [kg/pc.]
VNMW 0,5 t	500	1-20	205	102	40	462	224	48	80	14	6
VSNMW 0,5 t	500	17-37	205	102	40	462	241	48	80	14	6
VNMW 1 t	1.000	1-30	232	105	40	470	282	46	80	14	6,50
VNMW 1,5 t	1.500	1-40	232	105	40	470	282	46	80	14	6,50
VNMW 2 t	2.000	1-50	362	124	50	704	408	63	80	18	15
VNMW 3 t	3.000	1-60	362	124	50	704	408	63	80	18	15,50

## VNMAW pewag winner vertical lifting clamps

This special clamp is fitted with two clamp jaws made from a synthetic material that leave no imprint on the material to be lifted during use, making it particularly suited for moving, lifting and lowering special materials such as stainless steels (Inox), aluminium sheet metal, wooden boards and chipboard. The clamp is hooked directly onto the crane hook using a high-strength chain and has a load capacity of 0.5 t. The clamp is adjustable in 20 mm steps.

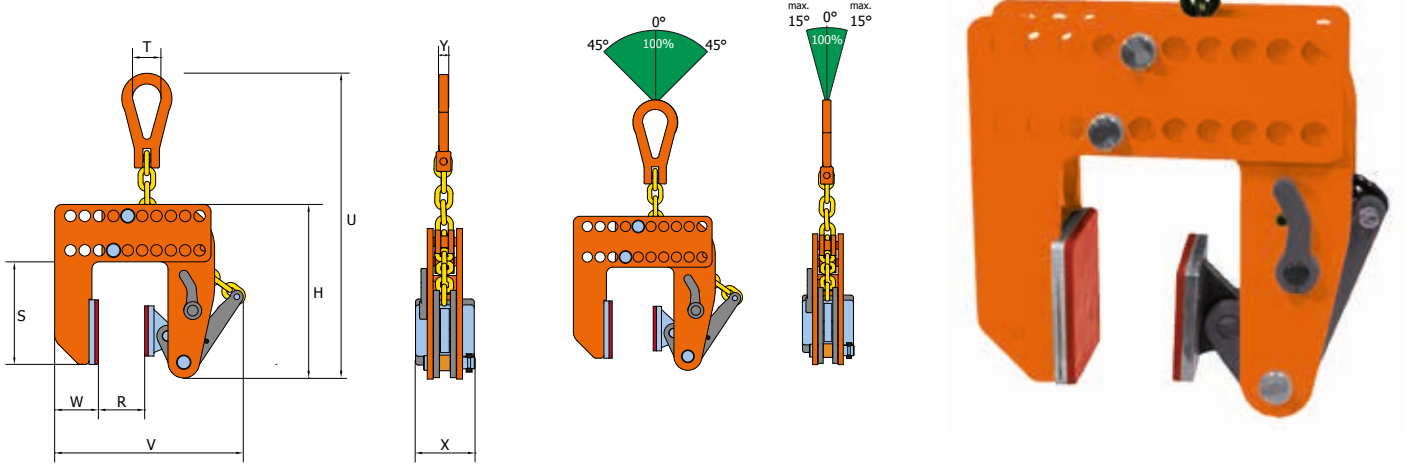

Code	Load capacity [kg]	Jaw-opening R [mm]	H [mm]	S [mm]	T [mm]	U [mm]	V [mm]	W [mm]	X [mm]	Y [mm]	Weight [kg/pc.]
VNMAW 0,5 t	500	1-180	242	143	40	410	235-395	61	80	14	10

## VJPW pewag winner vertical lifting clamps

For vertical lifting and moving of panels and plates.  
 If the clamp is being loaded, the cams will pull out sideways and will grip into the sides of the load.  
 The VJPW clamp is locked in closed as well as in open position.  
 Lifting capacity and jaw opening are clearly engraved in the body.  
 Clamp type VJPUW is equipped with a moveable lifting shackle.  
 This clamp has no restriction for a minimum working load.

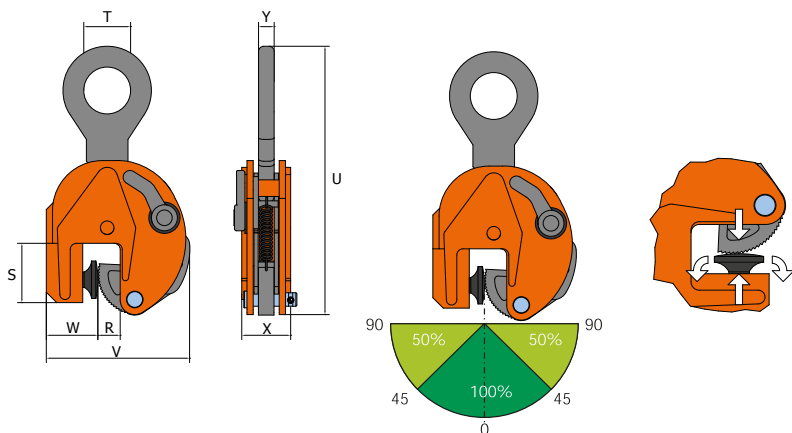

Code	Load capacity [kg]	Jaw-opening R [mm]	S [mm]	T [mm]	U [mm]	V [mm]	W [mm]	X [mm]	Y [mm]	Weight [kg/pc.]
VJPW 0,25 t	250	0-13	54	30	202	113	50	37	10	1,90
VJPUW 0,25 t	250	0-13	54	30	202	113	50	37	10	2



## BKW pewag winner vertical lifting clamps

For lifting and moving of steel beams, profiles and structures where the load must stay in position. The special shape of the lifting shackle places the centre of the gravity of the beam beneath the lifting shackle. This maintains the equilibrium of the beam once it has been lifted and keeps the flanges vertical so that the beam can easily be stacked or positioned. Recommended for moving and stacking of steelbeams. Lifting capacity and jaw-opening are clearly engraved in the body.

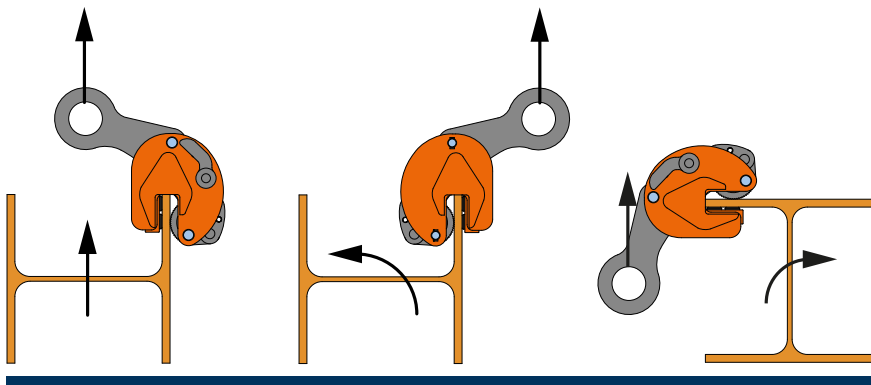
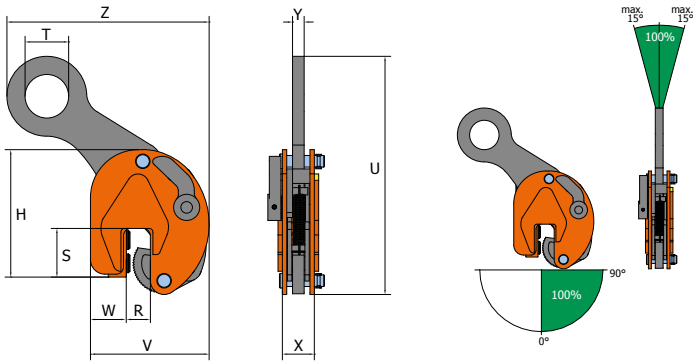

Code	Load capacity [kg]	Jaw-opening R [mm]	V [mm]	W [mm]	S [mm]	H [mm]	T [mm]	Z [mm]	X [mm]	U [mm]	Y [mm]	Weight [kg/pc.]
BKW 1 t	1.000	0-15	136	43	45	154	35	200	47	225	15	3
BKW 1,5 t	1.500	0-20	170	56	67	210	60	312	56	374	16	7
BKW 3 t	3.000	0-25	208	58	66	252	70	380	77	410	20	15

## OBKW pewag winner vertical lifting clamps

For lifting and moving of steel beams, profiles and structures. Because of the safety mechanism, the OBKW clamp is locked in closed as well as in open position.

The clamp is suitable to lift steel beams on the flange as well as on the upper ends of the beam.

Other jaw-openings and Working Load Limits are available upon request.

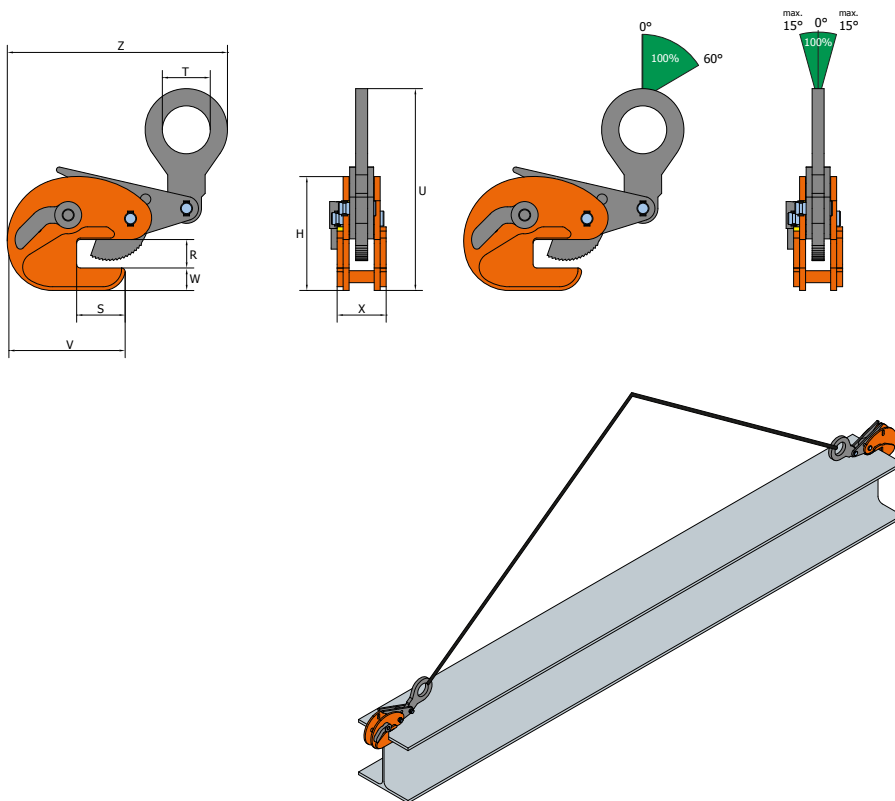

Code	Load capacity [kg]	Jaw-opening R [mm]	V [mm]	W [mm]	S [mm]	H [mm]	T [mm]	Z [mm]	X [mm]	U [mm]	Y [mm]	Weight [kg/pc.]
OBKW 2 t	2.000	3-20	192	30	64	154	64	285	65	310	15	6,80

## pewag winner vertical lifting clamps with an extra hardened pivot and cam (H)

Equipped with an extra hardened pivot and cam for lifting and transporting steel plates with a hardness of max. 50 Hrc (Hardox 400 and 500). These extra-hardened components may be used with clamp types VCW (VCEW), VMPW (VEMPW) and VUW (VEUW). Further customized versions with other capacity and jaw-opening available upon request.



Code	Load capacity [kg]	Jaw-opening R [mm]	S [mm]	T [mm]	U [mm]	V [mm]	W [mm]	X [mm]	Y [mm]	Weight [kg/pc.]
VCW-H 0,75 t	750	0-13	47	30	202	100	37	37	10	1,70
VCEW-H 1 t	1.000	0-25	56	45	263	141	37	47	15	3,50
VCEW-H 2 t	2.000	0-35	78	64	336	183	56	56	16	7
VCEW-H 3 t	3.000	0-35	78	64	336	183	56	56	16	7
VCEW-H 4,5 t	4.500	0-45	85	70	425	228	60	78	20	16
VCW-H 6 t	6.000	0-32	114	75	490	225	78	78	20	19
VCEW-H 7,5 t	7.500	0-55	111	75	522	267	70	86	20	26
VMPW-H 0,75 t	750	0-13	47	30	307	100	37	37	10	2
VEMPW-H 1 t	1.000	0-25	56	45	403	141	37	47	15	4,50
VEMPW-H 2 t	2.000	0-35	78	64	516	183	56	56	16	8
VEMPW-H 3 t	3.000	0-35	78	64	516	183	56	56	16	8
VEMPW-H 4,5 t	4.500	0-45	85	70	650	228	60	78	20	19
VMPW-H 6 t	6.000	0-32	114	75	760	225	78	78	20	24
VEMPW-H 7,5 t	7.500	0-55	111	75	792	267	70	86	20	30,50
VUW-H 0,75 t	750	0-13	47	30	203	100	37	37	10	1,80
VEUW-H 1 t	1.000	0-25	56	50	292	141	37	47	15	3,80
VEUW-H 2 t	2.000	0-35	78	70	372	183	56	56	16	8
VEUW-H 3 t	3.000	0-35	78	70	372	183	56	56	16	8
VEUW-H 4,5 t	4.500	0-45	85	70	431	228	60	78	20	16,50
VUW-H 6 t	6.000	0-40	114	78	528	225	78	78	32	22
VEUW-H 7,5 t	7.500	0-55	111	78	560	267	70	86	32	28

Turn to pages 16, 17 and 18 to find the right dimension.

# pewag winner horizontal lifting clamps

## Product Overview

Content 28

### pewag winner horizontal lifting clamps

HXW/HSXW pewag winner horizontal lifting clamps	30
DHW pewag winner horizontal lifting clamps	31
HSKW pewag winner horizontal lifting clamps	32
HXW-V pewag winner horizontal lifting clamps	33
NMHW pewag winner horizontal lifting clamps	34



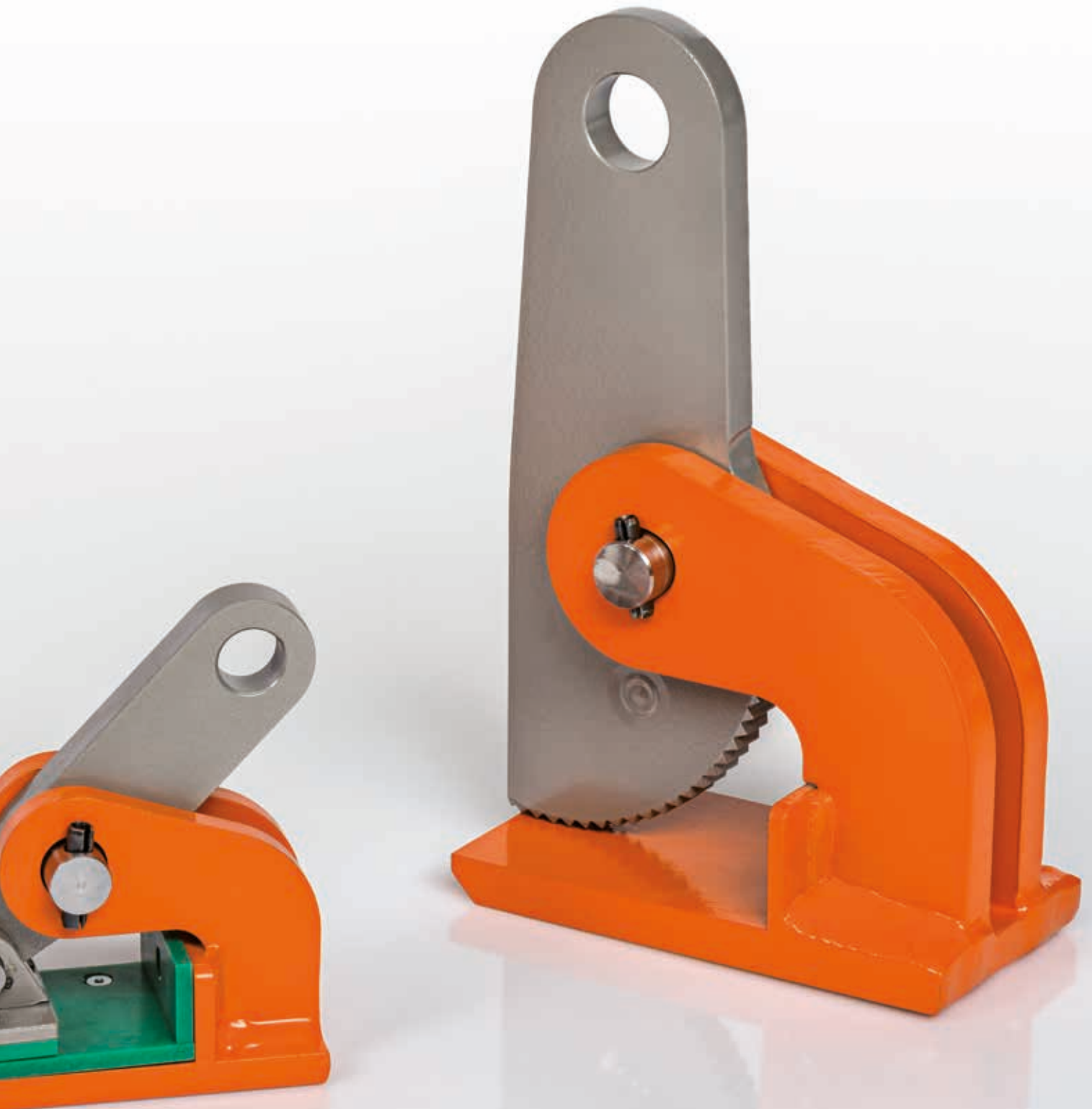

## HXW/HSXW pewag winner horizontal lifting clamps

For horizontal lifting and moving of steel plates.  
 Clamp with compact shape and relative light unit weight – but with a high lifting capacity. HXW/HSXW pewag winner lifting clamps **must always be used in pairs (or multiples thereof)**. Lifting capacity and jaw opening are clearly engraved in the body. The Working Load Limits indicated are per pair of lifting clamps. The HSXW clamps have a larger jaw opening.

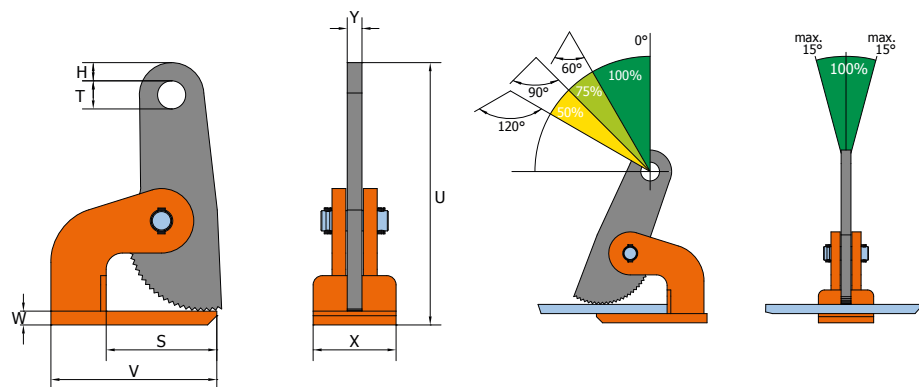

Code	Load capacity [kg/pair]	Jaw-opening R [mm]	V [mm]	S [mm]	W [mm]	T [mm]	H [mm]	X [mm]	U [mm]	Y [mm]	Weight [kg/pc.]
HXW 1 t	1.000	0-35	140	99	10	25	11,50	65	188	15	2,60
HXW 2 t	2.000	0-60	180	118	15	30,50	19,50	90	287	16	7
HXW 3 t	3.000	0-60	180	118	20	30,50	19,50	90	291	16	8
HXW 4 t	4.000	0-60	220	145	25	30,50	19,50	105	304	20	13
HXW 6 t	6.000	0-60	220	145	25	30,50	19,50	110	307	20	14
HXW 8 t	8.000	0-60	225	135	35	30,50	19,50	120	336	30	19
HXW 10 t	10.000	0-60	225	135	35	30,50	19,50	120	336	30	19
HXW 12 t	12.000	0-60	225	135	35	30,50	19,50	120	336	30	19
HSXW 2 t	2.000	0-100	180	120	15	30,50	19,50	90	383	15	9,20
HSXW 3 t	3.000	0-100	180	120	20	30,50	19,50	90	387	15	10
HSXW 4 t	4.000	0-100	220	145	25	30,50	19,50	105	414	20	15
HSXW 6 t	6.000	0-100	220	145	25	30,50	19,50	120	414	20	16,50
HSXW 8 t	8.000	0-100	225	135	35	30,50	19,50	120	428	30	21
HSXW 10 t	10.000	0-100	225	135	35	30,50	19,50	120	428	30	22
HSXW 12 t	12.000	0-100	225	135	35	30,50	19,50	120	428	30	22
HSXW 15 t	15.000	0-150	350	240	35	45	27,50	140	665	35	53

## DHW pewag winner horizontal lifting clamps

For lifting and horizontal moving of thin sheets that deflect when being lifted. Compact shape and relatively low unit weights with a high lifting capacity.

Horizontal lifting clamps DHW **must always be used in pairs (or multiples thereof)**. Max. apex angle: 60°

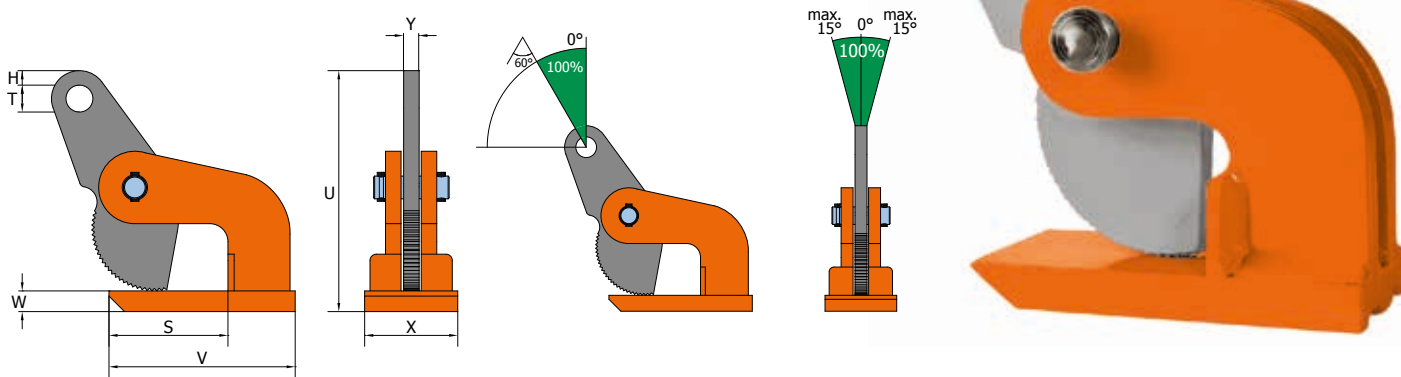

Code	Load capacity [kg/pair]	Jaw-opening R [mm]	V [mm]	S [mm]	W [mm]	T [mm]	H [mm]	X [mm]	U [mm]	Y [mm]	Weight [kg/pc.]
DHW 1 t	1.000	0-15	140	99	10	22,50	13,50	65	167	15	2,50
DHW 2 t	2.000	0-35	180	114	20	26	14	80	233	15	8
DHW 4 t	4.000	0-50	235	129	30	40	25	130	304	20	18
DHW 6 t	6.000	0-50	235	129	30	40	25	130	304	20	18

## HSKW pewag winner horizontal lifting clamps

For lifting, handling and moving of banded/secured stacks and single steel plates. The HSKW horizontal lifting clamps **must always be used in pairs**. The use of two pairs by means of a load spreader bar is also possible.

Capacity 1.5 tons per pair up to 9 tons per pair. Opening 3 – 180 mm, 3 – 300 mm and 3 – 420 mm.

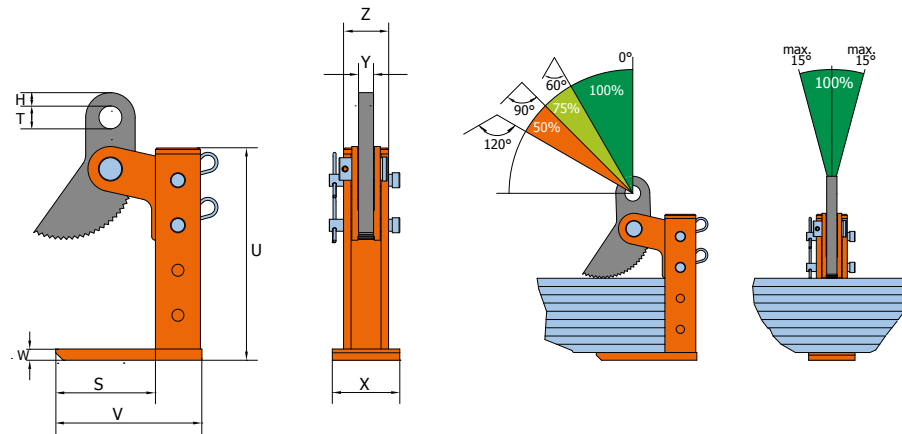

Code	Load capacity [kg/pair]	Jaw-opening R [mm]	V [mm]	S [mm]	W [mm]	T [mm]	H [mm]	U [mm]	X [mm]	Z [mm]	Y [mm]	Weight [kg/pc.]
HSKW/180 1,5 t	1.500	3-180	201	135	15	30,50	18	289	90	60	20	9,50
HSKW/300 1,5 t	1.500	3-300	201	135	15	30,50	18	409	90	60	20	11
HSKW/180 3 t	3.000	3-180	241	165	20	30,50	18	296	105	69	20	13
HSKW/300 3 t	3.000	3-300	241	165	20	30,50	18	416	105	69	20	15
HSKW/180 4,5 t	4.500	3-180	241	165	20	30,50	18	296	105	69	20	13
HSKW/420 4,5 t	4.500	3-420	241	165	20	30,50	18	536	105	69	20	17
HSKW/180 6 t	6.000	3-180	256	160	25	30,50	18	304	120	75	20	18
HSKW/420 6 t	6.000	3-420	256	160	25	30,50	18	544	120	75	20	24
HSKW/180 9 t	9.000	3-180	256	160	25	30,50	18	304	120	75	20	18
HSKW/420 9 t	9000	3-420	256	160	25	30,5	18	544	120	75	20	24



## HXW-V pewag winner horizontal lifting clamps

The HXW-V horizontal lifting clamps has a spring attached to the cam assembly allowing the clamp to close on any desired spot.

The spring allows one operator to place the clamps and guide the hoist. HXW-V horizontal lifting clamps **must always be used in pairs (or multiples thereof)**. Lifting clamps HXW-V are available with a capacity from 1.000 kg per pair to 6.000 kg per pair.

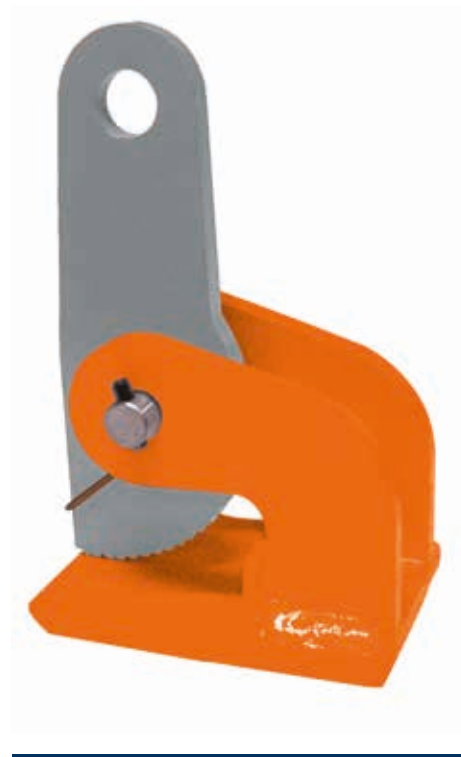
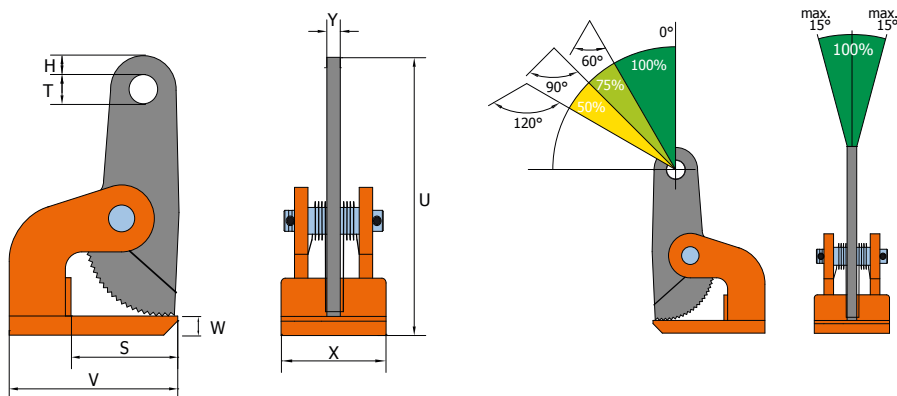

Code	Load capacity [kg/pair]	Jaw-opening R [mm]	V [mm]	S [mm]	W [mm]	T [mm]	H [mm]	U [mm]	X [mm]	Y [mm]	Weight [kg/pc.]
HXW-V 1 t	1.000	0-35	140	99	10	26,50	12	188	85	15	3
HXW-V 2 t	2.000	0-60	180	114	15	30,50	19	286	125	16	8
HXW-V 3 t	3.000	0-60	200	125	20	30,50	19	302	140	20	12,20
HXW-V 4 t	4.000	0-60	220	139	30	30,50	19	316	165	20	17
HXW-V 6 t	6.000	0-60	220	139	30	30,50	19	316	165	20	17

## NMHW pewag winner horizontal lifting clamps

The NMHW lifting clamp is suited for moving and lifting objects with fragile surfaces, like stainless steel, wood panels, aluminium etc. The jaw and cam is covered with a high quality, pressure resistant protective cover. NMHW horizontal lifting clamps **must always be used in pairs (or multiples thereof)**.

NMHW lifting clamps are available with a capacity from 1.000 kg per pair to 6.000 kg per pair.

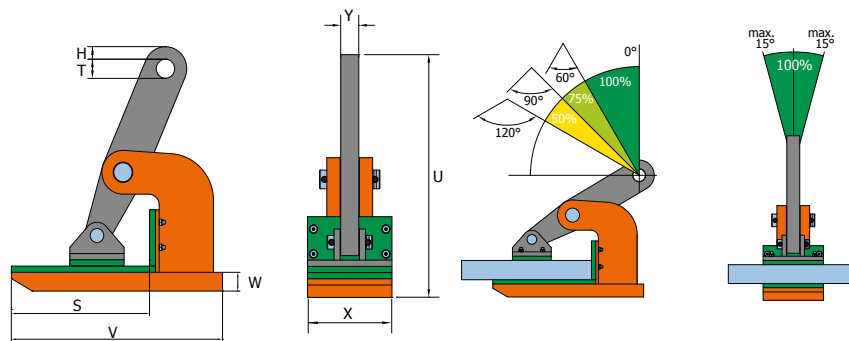

Code	Load capacity [kg/pair]	Jaw-opening R [mm]	V [mm]	S [mm]	W [mm]	T [mm]	H [mm]	U [mm]	X [mm]	Y [mm]	Weight [kg/pc.]
NMHW 1 t	1.000	0-25	140	94	15	20	10	155	65	15	2,40
NMHW 2 t	2.000	0-45	225	151	23	30,50	15	267	90	15	7,5
NMHW 3 t	3.000	0-45	225	151	20	30,50	15	271	90	15	8,30
NMHW 4 t	4.000	0-50	250	161	20	30,50	17,50	300	115	30	13
NMHW 6 t	6.000	0-50	250	161	25	30,50	17,50	306	130	30	18

# pewag lifting clamps – a passion for innovation.



# pewag winner screw clamps

## Product Overview

Content 36

### pewag winner screw clamps

SVW/SVSW/SVSUW pewag winner screw clamps 38  
SCCW pewag winner screw clamps 39  
BSW pewag winner screw clamps shipbuilding 40





## SVW/SVSW/SVSUW pewag winner screw clamps

Only suitable for lifting and moving of steel beams and structures. The clamping force is evenly transferred to the jaws by means of a spindle. Can also be attached upside down and be used as a (temporary) lifting point. Has equal opening and closing of both jaws for simple and quick assembly. Lifting capacity and jaw opening are clearly engraved in the body.

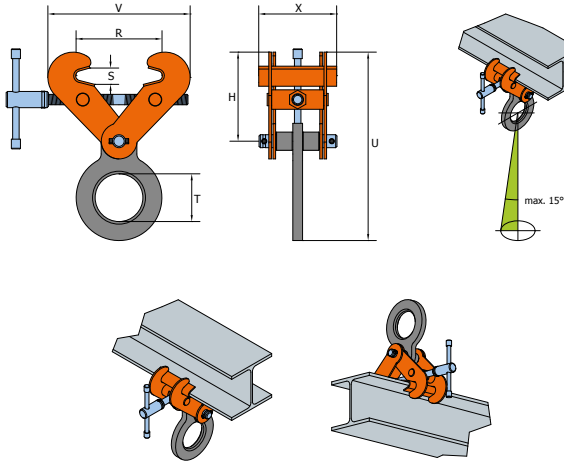

### SVSUW

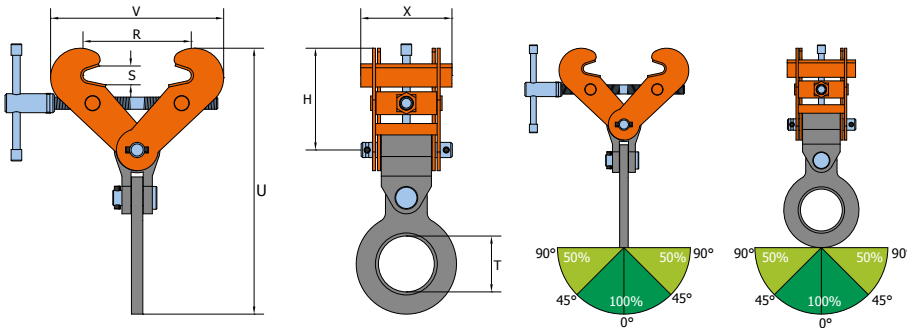

Code	Load capacity [kg]	Jaw-opening R [mm]	S [mm]	T [mm]	V-max [mm]	U-max [mm]	H [mm]	X [mm]	Weight [kg/pc.]
SVW 1 t	1.000	75-190	30	73,50	357	345	113-192	120	5
SVW 2 t	2.000	75-190	30	73,50	357	345	113-192	120	5
SVW 3 t	3.000	75-190	30	73,50	357	345	113-192	120	5
SVW 4 t	4.000	150-300	40	80	450	422	185-240	180	15
SVW 5 t	5.000	150-300	40	80	450	422	185-240	180	15
SVW 10 t	10.000	350-450	95	88	695	653	400-447	200	50
SVSW 2 t	2.000	75-420	30	73,50	540	428	114-275	120	7
SVSW 3 t	3.000	75-420	30	73,50	540	428	114-275	120	7
SVSW 4 t	4.000	150-560	40	80	708	545	173-362	180	18
SVSW 5 t	5.000	150-560	40	80	708	545	173-362	180	19,50
SVSUW 3 t	3.000	75-420	30	73,50	540	486	114-275	120	8
SVSUW 4 t	4.000	150-560	40	80	708	613	173-362	180	21
SVSUW 5 t	5.000	150-560	40	80	708	622	173-362	180	22

# SCCW pewag winner screw clamps

Universal screw clamp for vertical and horizontal lifting and moving of a large variety of steel structures.

The SCCW screw clamp is fitted with a moveable cam on the thread spindle and a fixed pivot on the clampbody. This provides a powerful clamping force on the workpiece. The moveable lifting eye ensures a secure mounting of the clamp.

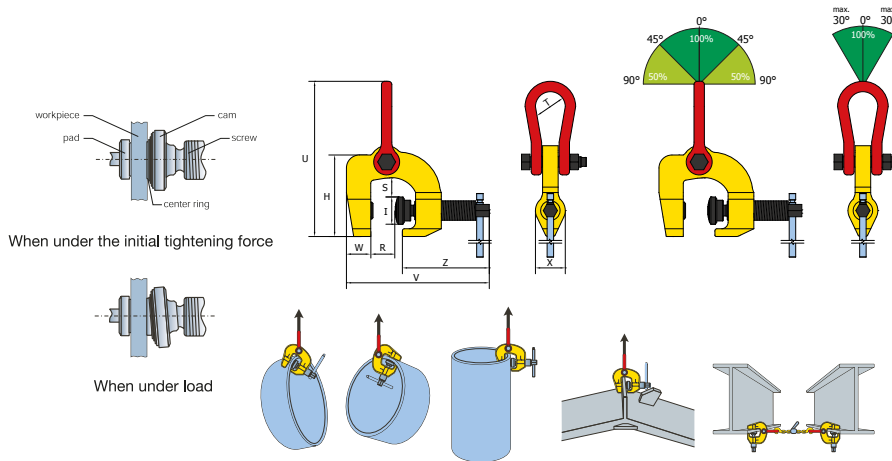

Code	Load capacity [kg]	Jaw-opening R [mm]	S [mm]	I [mm]	W [mm]	V [mm]	Z [mm]	U [mm]	H [mm]	T [mm]	X [mm]	Weight [kg/pc.]
SCCW 0,5 t	500	0-35	18	27,50	26	108	158	211	82	25	27	1
SCCW 1 t	1.000	0-30	44	42	46	210	175	204	128	38	46	3,20
SCCW 1,5 t	1.500	0-40	29	42	40	150	220	232	140	46	46	3,50
SCCW 3 t	3.000	0-60	38	50	46	190	280	278	184	50	60	7,80
SCCW 6 t	6.000	0-75	76	63	76	255	291	365	214	80	69	18
SCCW-W 1 t	1.000	50-100	88	42	54	225	258	273	190	45	46	6
SCCW-W 3 t	3.000	25-75	76	49	60	215	250	291	191	50	54	7,80

## BSW pewag winner screw clamps shipbuilding

For use as a temporary lifting point in any room where HP-profile is being used, such as sectional ship parts and ship engine rooms. The BSW clamp is equipped with a thread spindle for attaching the clamp. The clamp is used for HP-100 to HP-240 (HP = Hollandprofile).

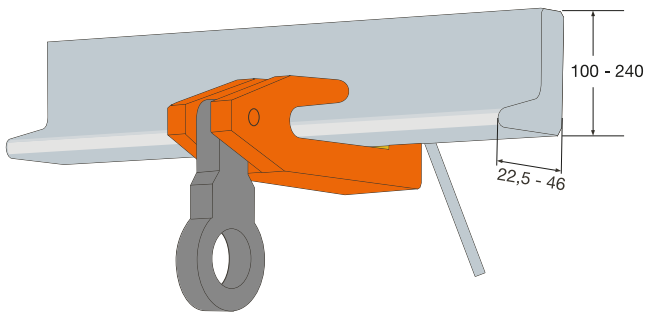
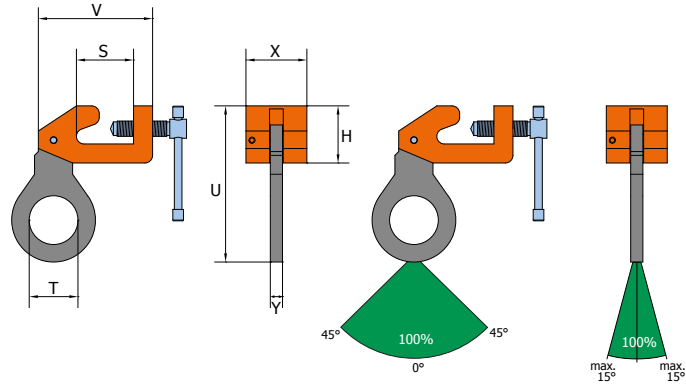

Code	Load capacity [kg]	Jaw-opening R [mm]	V [mm]	S [mm]	T [mm]	U [mm]	H [mm]	X [mm]	Y [mm]	Weight [kg/pc.]
BSW 1,5 t	1.500	HP 100-240	150	74	45	180	75	40	16	2,90
BSW 3 t	3.000	HP 100-240	150	75	65	205	75	80	16	6



**We seek to improve our products on an ongoing basis and continuously look for new solutions.**



# pewag winner drum clamps

## Product Overview

Content 42

### pewag winner drum clamps

VKFW pewag winner drum clamps 44  
VKHW pewag winner drum clamps 44  
VSHW pewag winner drum clamps 45





## VKFW pewag winner drum clamps

Special clamp for safe lifting and moving of steel (oil) drums.  
The automatic locking mechanism of VKFW clamps ensures a safe transport of drums.  
VKFW steel drum clamps can be used in pairs or single.

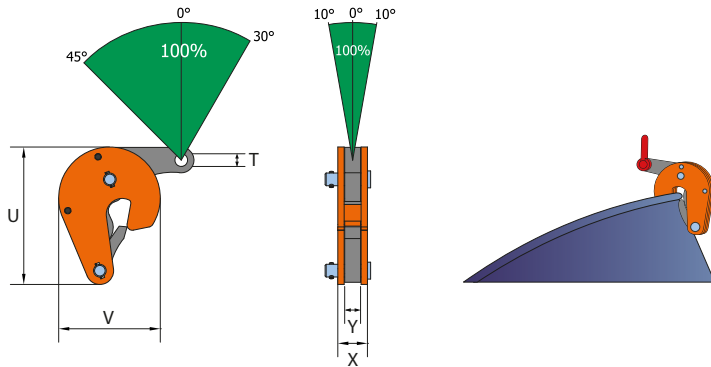

Code	Load capacity [kg]	Jaw-opening R [mm]	U [mm]	V [mm]	T [mm]	X [mm]	Y [mm]	Weight [kg/pc.]
VKFW 0,5 t	500	0-17	121	96	12	28	15	1,30

## VKHW pewag winner drum clamps

For lifting, handling and moving of steel (oil)drums, where the drums have to stay in a vertical position.  
These VKHW clamps should preferably be used only with closed drums. Capacity 0.6 tons.

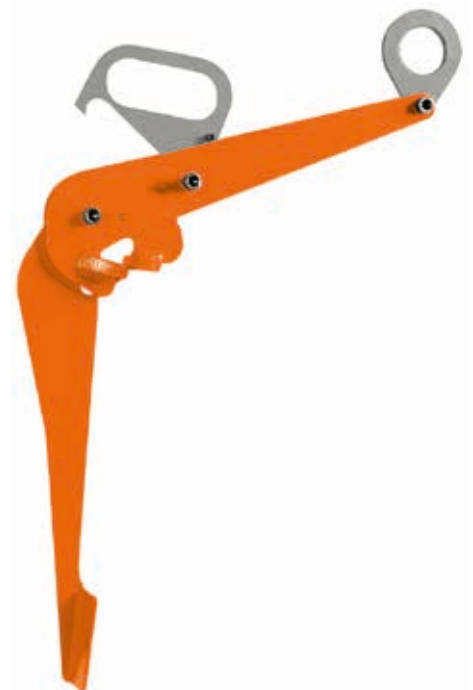
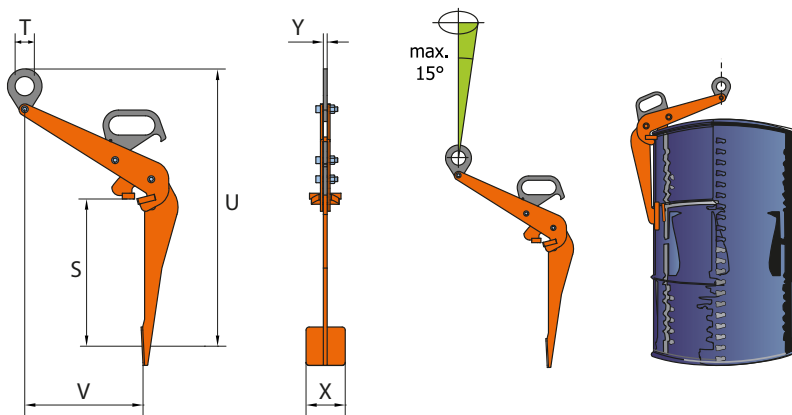

Code	Load capacity [kg]	Jaw-opening R [mm]	U [mm]	S [mm]	V [mm]	T [mm]	X [mm]	Y [mm]	Weight [kg/pc.]
VKHW 0.6 t	600		765	434	305	50	100	10	7

## VSHW pewag winner drum clamps

This barrel gripper is designed for moving, lifting and lowering horizontally stored barrels (horizontal moving).

The barrel gripper should preferably be used for closed barrels.

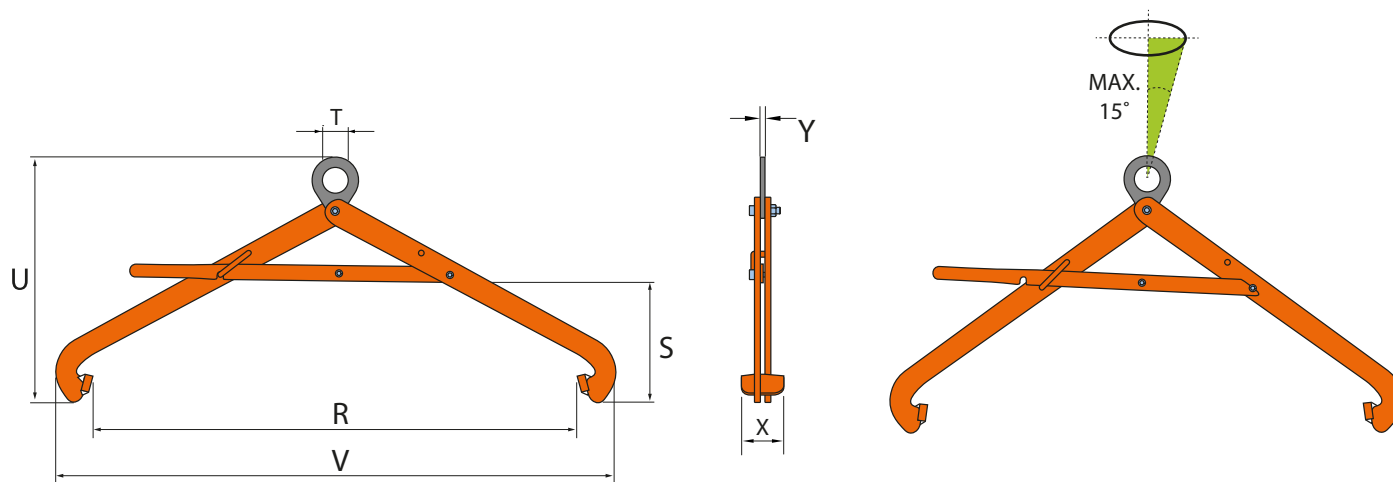

Code	Load capacity [kg]	Jaw-opening R [mm]	U [mm]	S [mm]	V [mm]	T [mm]	X [mm]	Y [mm]	Weight [kg/pc.]
VSHW 0,6 t	600	500-900	475	230	1080	50	82	10	7

# pewag winner special clamps and -grabs

## Product Overview

Content 46

### pewag winner special clamps and grabs

PHW/PHW-HD pewag winner pipe hook	48
BCW/BCW-A pewag winner pipe lifting clamp	49
TLW pewag winner special grabs	50
BLCW pewag winner special grabs	51





## PHW/PHW-HD pewag winner pipe hook

For horizontal lifting and moving of steel and concrete pipes. Compact shape and relatively low unit weight with a high lifting capacity. The surface is equipped with "special" plastic cover. Plastic cover replacement parts are available and easy to change.

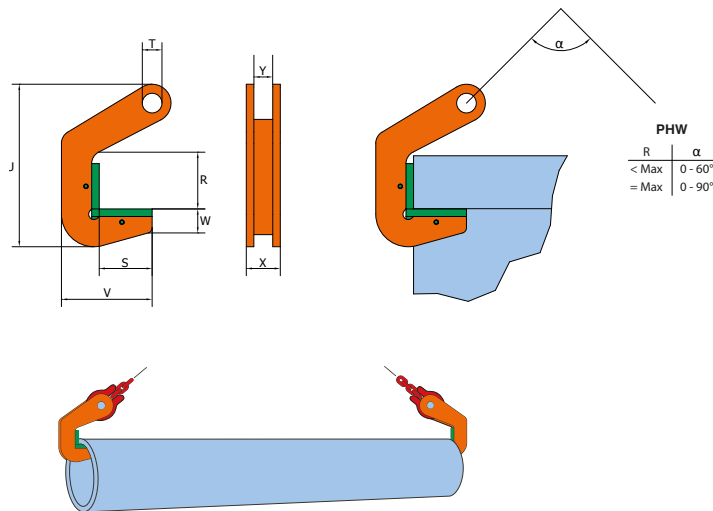
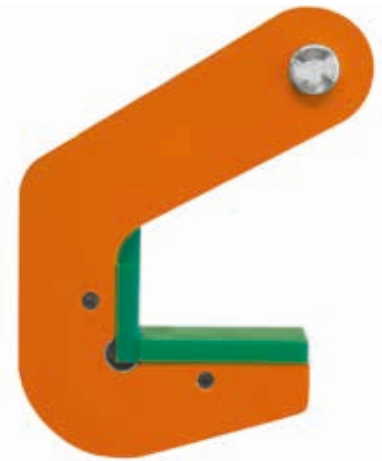

### PHW-HD

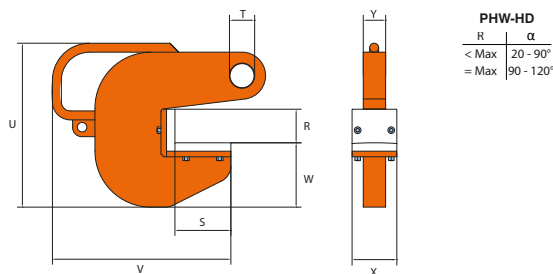

Code	Load capacity [kg/pair]	Jaw-opening R [mm]	V [mm]	S [mm]	W [mm]	U [mm]	T [mm]	X [mm]	Y [mm]	Weight [kg/pc.]
PHW 1,5 t	1.500	40	120	70	50	185	16	41	25	2
PHW 3 t	3.000	40	120	70	50	185	16	41	25	2
PHW 4 t	4.000	50	140	70	58	204	26	41	25	3
PHW 6 t	6.000	50	140	70	58	204	26	41	25	3
PHW 8 t	8.000	70	140	70	58	224	26	45	25	3,40
PHW 10 t	10.000	70	140	70	58	224	26	85	45	7
PHW 12 t	12.000	70	140	70	58	224	26	85	45	7
PHW 15 t	15.000	70	155	70	76	250	26	100	60	9
PHW 20 t	20.000	70	155	70	76	250	26	100	60	9
PHW-HD 5 t	5.000	60	271	100	85	230	26	80	20	6,70
PHW-HD 10 t	10.000	60	271	100	85	230	26	80	30	9,70
PHW-HD 20 t	20.000	60	291	100	105	269	36	80	35	14
PHW-HD 30 t	30.000	60	309	100	115	293	43	80	40	19
PHW-HD 60 t	60.000	60	309	100	115	313	62	80	60	28,50



## BCW/BCW-A pewag winner pipe lifting clamp

These clamps are preferably used for vertical lifting and moving of concrete pipes and wells. BCW/BCW-A clamps must always be used in pairs or per three clamps in combination with a chain sling. The moveable side is fitted with a “special” high pressure plastic cover to protect load surface. High tensile two- or three leg chain slings available upon request.

BCW-A: R min. 50 mm/max. 220 mm  
Adjustable in steps of 25 mm.

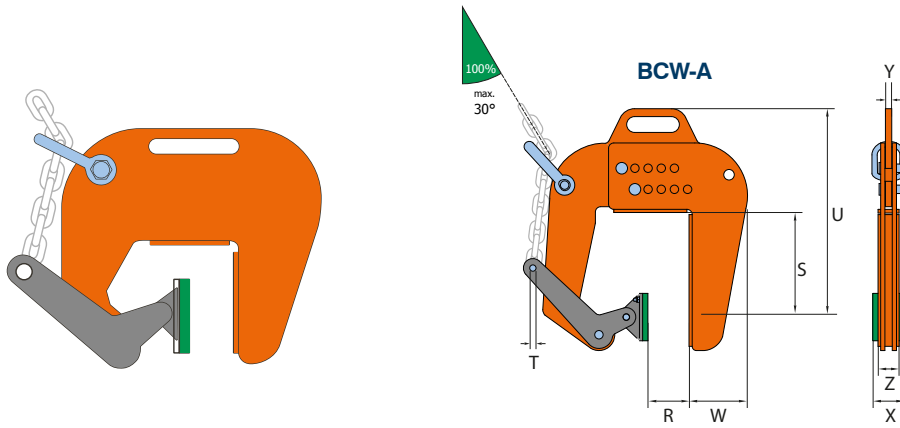

Code	Load capacity [kg]	Jaw-opening R [mm]	U [mm]	S [mm]	W [mm]	T [mm]	X [mm]	Z [mm]	Y [mm]	Weight [kg/pc.]
BCW 1 t	1.000	60-120	326	169	97	12	60	40	12	10
BCW-A 1 t	1.000	50-220	459	262	106	12	60	40	12	15

## TLW pewag winner special grab

For vertical lifting of tubes, bundles of tubes and solid round material.

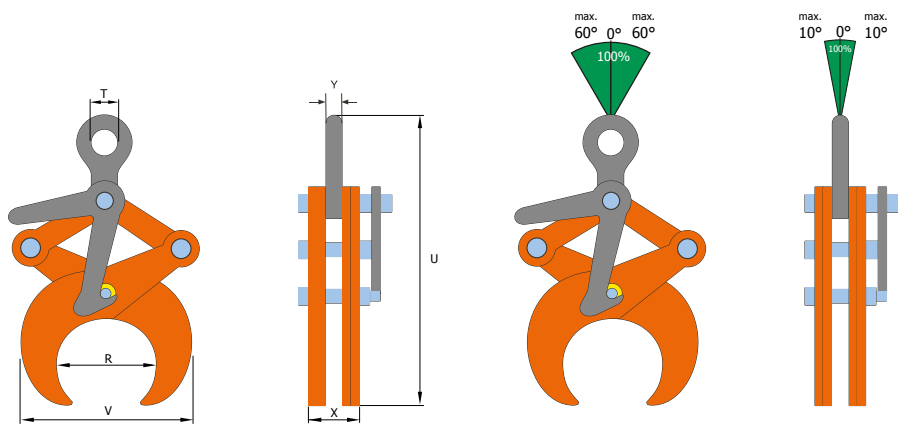

Code	Load capacity [kg]	Jaw-opening R [mm]	V min-max [mm]	U min-max [mm]	T [mm]	X [mm]	Y [mm]	Weight [kg/pc.]
TLW 0,5 t	500	48,3-114,3	146-207	300-400	45	47	15	4,50
TLW 1 t	1.000	114,3-219,1	110-170	430-615	45	47	15	9
TLW 2 t	2.000	219,1-368	490-610	670-955	64	56	16	31
TLW 3 t	3.000	368-508	590-710	875-1165	64	56	16	39

## BLCW pewag winner special grab

For vertical lifting and moving of various materials as steel, wood, plastic, concrete, marble etc. which have parallel sides. The clamp is locked in the open position. To perform lifting, the operator must activate the handle and hold it up while the force on the lifting eye is going upwards. When laying down the load, the clamp automatically unlocks itself to open.

The pads are covered with special plastic to avoid damage of contact surfaces.

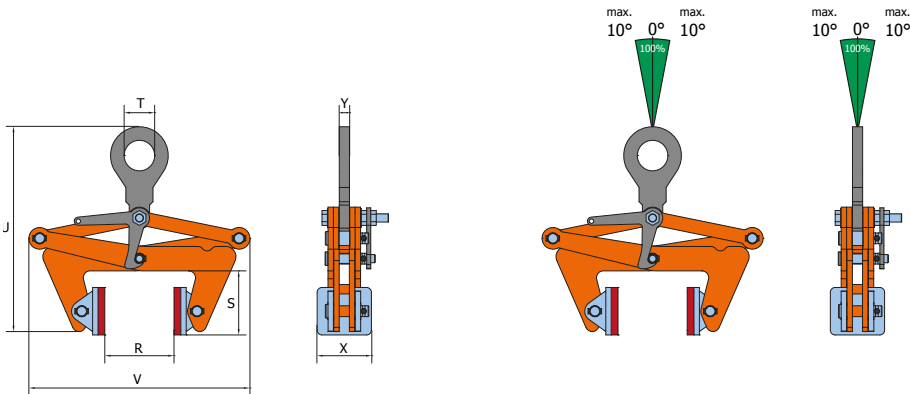

Code	Load capacity [kg]	Jaw-opening R [mm]	V min-max [mm]	U min-max [mm]	S [mm]	T [mm]	X [mm]	Y [mm]	Weight [kg/pc.]
BLCW 0,5 t	500	30 - 110	270-325	305-460	95	45	80 (*70)	15	7
BLCW 1 t	1.000	100 - 230	425-530	380-655	120	45	80 (*70)	15	12,30
BLCW 2 t	2.000	220 - 360	580-675	410-735	140	45	80 (*70)	15	18
BLCW 3 t	3.000	350 - 500	725-835	530-900	178	64	100 (*90)	16	33

# pewag winner lifting clamps spare parts

## Product Overview

Content 52

### pewag winner lifting clamps spare parts

pewag winner clamp components – spare parts 54–55  
Risk-free lifting 55–56





## pewag winner clamp components – spare parts

All spare parts are available either separately or as repair sets. It is recommended when any parts are damaged to replace them right away. When ordering spare parts provide following information: model, lifting capacity, jaw opening and serial number as well as the needed spare parts.

- A Cam assembly
- B Lock lever assembly
- C Lock spring
- D Cam pin
- E Pivot complete
- F Shackle pin
- G Lifting eye for VCW, SVCW, VMPW, SVMPW model
- H Lifting eye for VUW, SVUW model
- I Hinge joint VMPW, SVMPW model
- J Link pin
- L Cam for HXW model
- M Cam pin for HXW model
- N Cam for HSXW model
- O Cam pin for HSXW model

For every vertical clamps are revision-sets and repair sets available.

### The repair sets contain:

- A Cam assembly
- C Lock spring
- D Cam pin
- E Pivot set

### The revision sets contain:

- A Cam assembly
- B Lock lever assembly
- C Lock spring
- D Cam pin
- E Pivot complete



Repair set

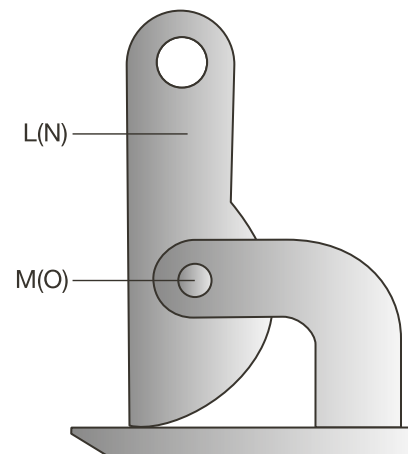
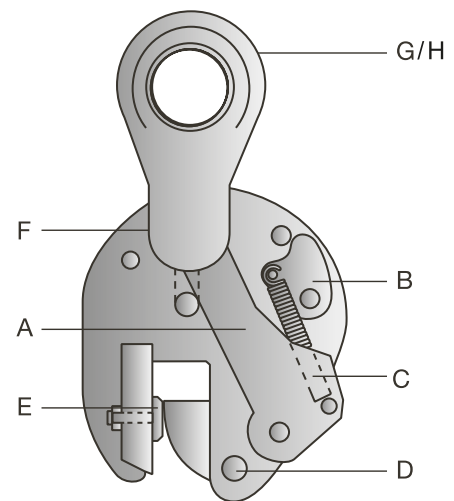

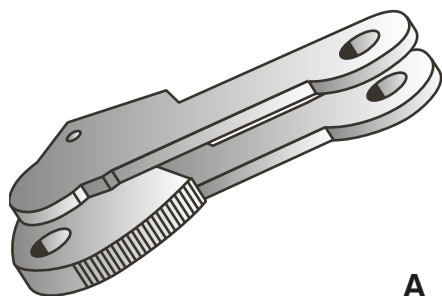

A



B



C

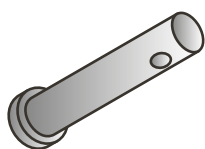

D

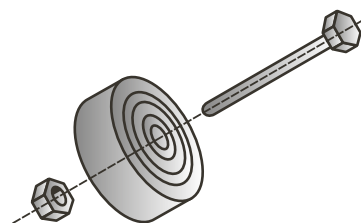

E

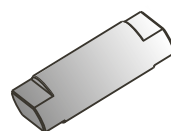

F

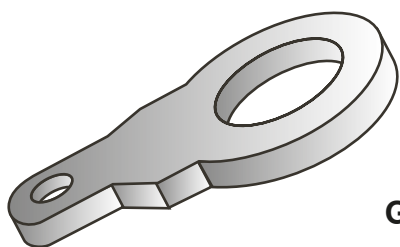

G

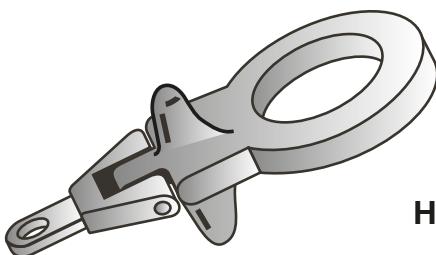

H

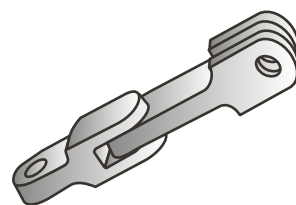

I

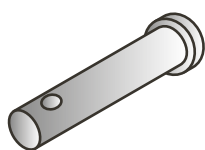

J

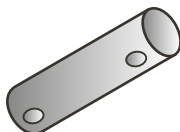

M(O)

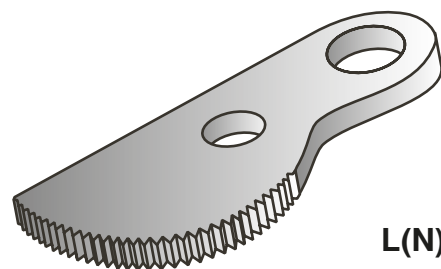

L(N)

## Risk-free lifting

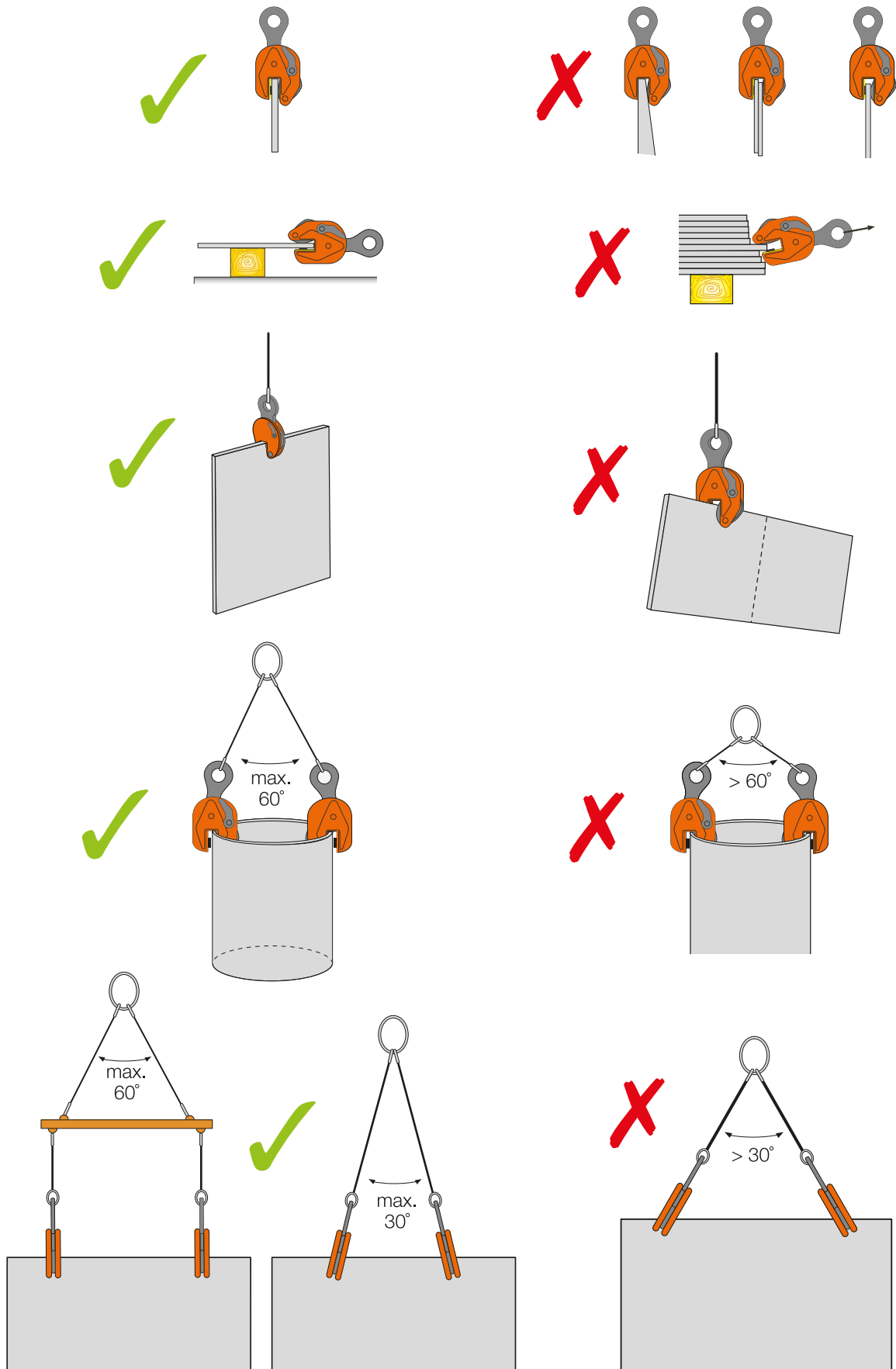



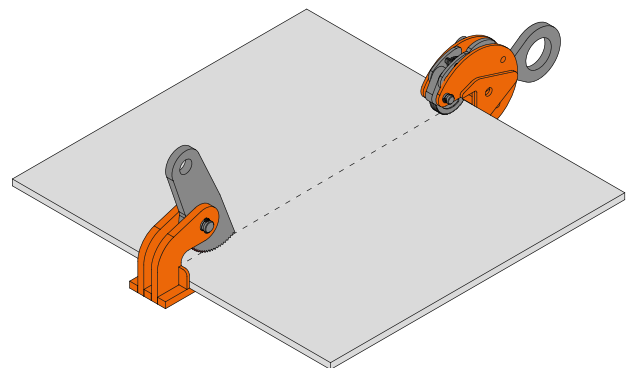
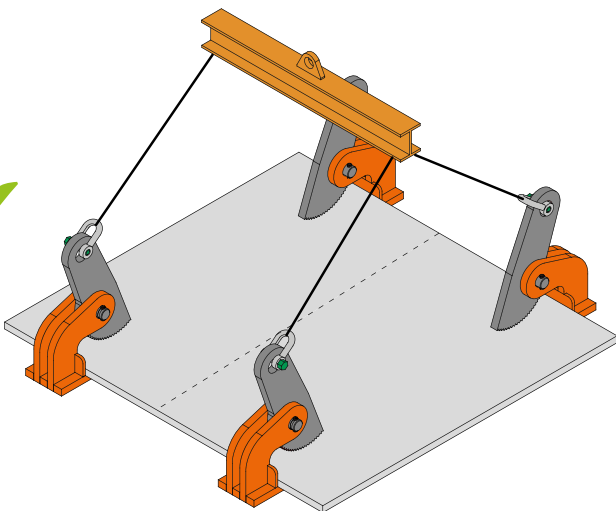
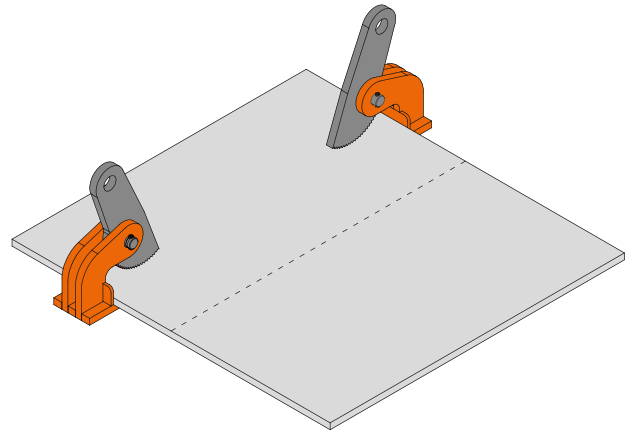
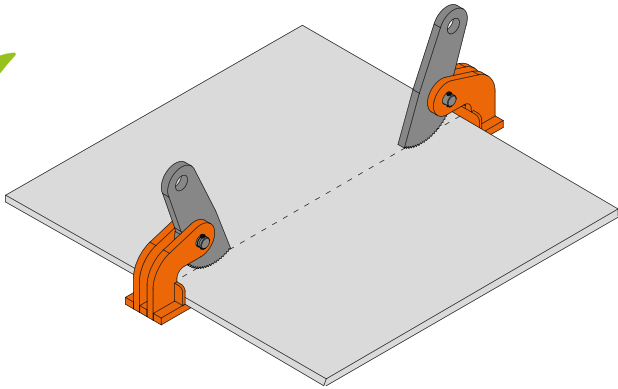
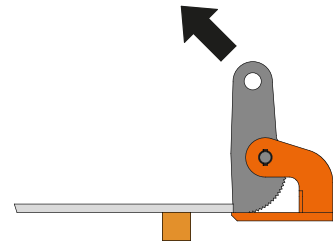
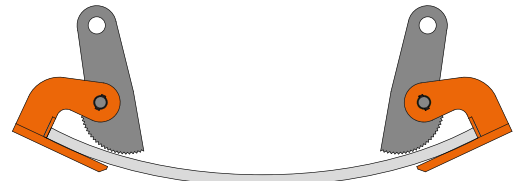
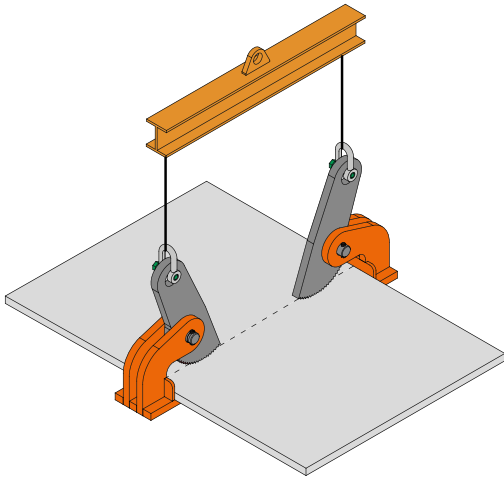



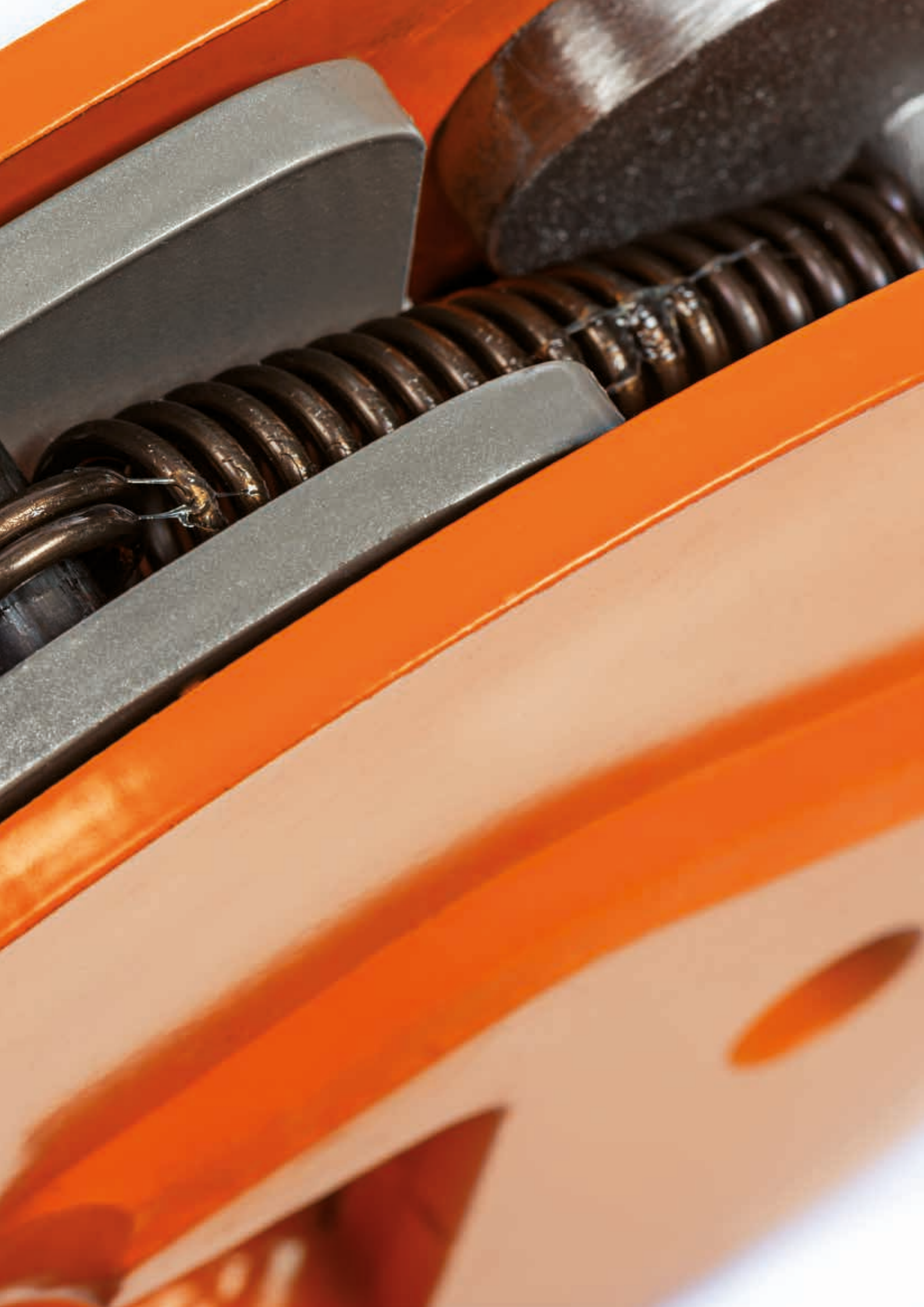



Promotion  
sustainable forest  
management



[www.pewag.com](http://www.pewag.com)

**pewag austria GmbH**

A-8041 Graz, Gaslaternenweg 4, Phone: +43 316 6070-0, Fax: +43 316 6070-100,  
[saleinfo@pewag.com](mailto:saleinfo@pewag.com), [www.pewag.com](http://www.pewag.com)

